

Structural Concrete Insulated Panels

by Gulf Concrete Technology (GCT)

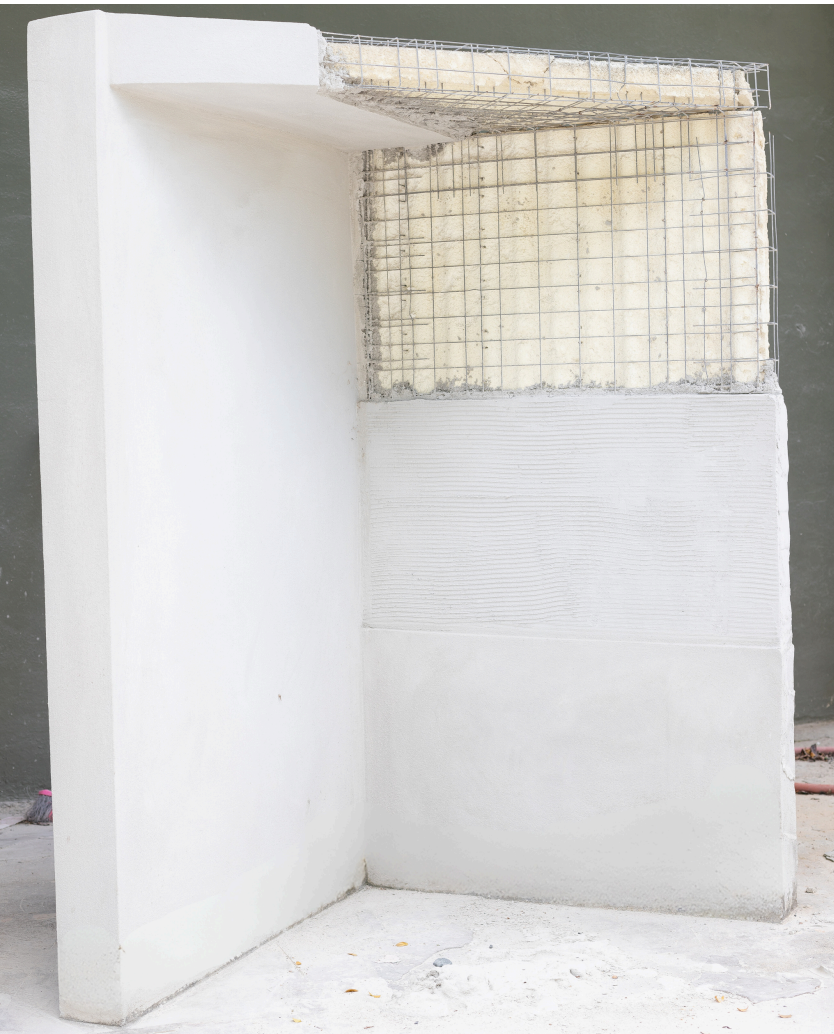

Technical Manual & Installation Guide



GULF CONCRETE TECHNOLOGY
Structural Insulated Building Components



www.structuralpanelsgct.com

4..... 1.0 INTRODUCTION

5..... 2.0 DESCRIPTION OF THE GCT STRUCTURAL BUILDING SYSTEM

6..... 3.0 CLASSIFICATION OF THE GCT PRODUCTS

12..... GCT RENDER MORTAR OR CEMENT PLASTER APPLICATION MACHINES FOR WALLS AND CEILINGS

INSTALLATION GUIDE

14..... INTRODUCTION

15..... CHECKLIST FOR HANDLING & INSTALLING THE GCT BUILDING SYSTEM

16..... GCT BUILDING SYSTEM: OUTLINE OF CONSTRUCTION

18 INSTALLATION

19..... GCT STRUCTURAL BUILDING SYSTEM ASSEMBLY

22..... GCT PANELS USED AS PARTITION WALLS REINFORCING MESHWORKS

27..... INSTALLATION OF CGT BUILDING SYSTEM FLOOR & ROOF SLABS (PSM, PSM HP OR PSG)

31..... INSTALLATION OF GCT STAIR PANELS

33..... PLUMBING, ELECTRIC INSTALLATION & OTHER SYSTEMS

34..... FINISHING DETAILS

36..... CARMELO STRUCTURAL MORTAR MIX HIGH STRENGTH MORTAR (4000 PSI)

38..... SINGLE PANEL PSM DETAIL SHEET

39..... SINGLE PANEL PSM HP DETAIL SHEET

40 SINGLE PANEL PSM SLAB DETAIL SHEET

41..... FLOOR PSG PANELS DETAIL SHEET

42..... STAIRCASE PANEL PSSC DETAIL SHEET

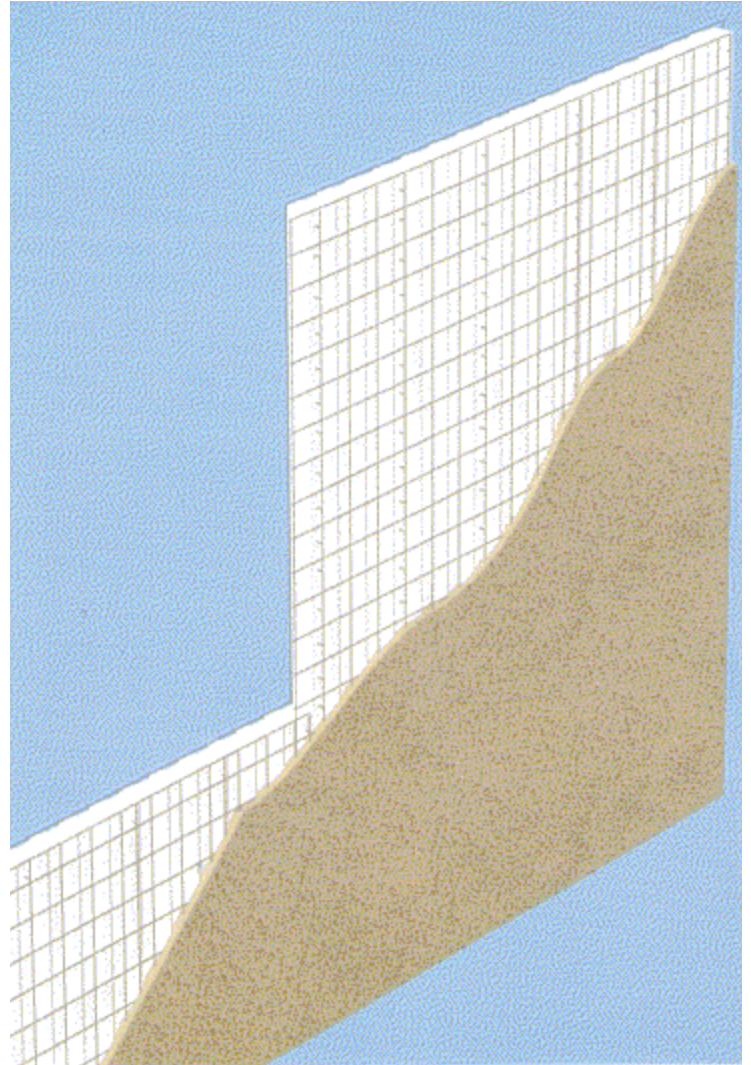

1.0 INTRODUCTION

Weather conditions around the world continue to grow more and more extreme. Building stronger and safer buildings is necessary to resist these environmental extremes. Furthermore, as stewards of our planet, building homes and businesses that are environmentally friendly and energy efficient is a necessity. That is where the GCT Structural Building System can help. Built to withstand hurricane force winds and wind driven rain, as well as wind borne debris, the GCT Structural Building System is an excellent choice for the safety conscious consumer. Additionally, the GCT Structural Building System is resistant to fire, tornadoes, flooding, termites and other bug infestation. Add the benefit of excellent energy efficiency, and the GCT Structural Building System is the best choice for building construction.

2.0 DESCRIPTION OF THE GCT STRUCTURAL BUILDING SYSTEM

2.1 FUNDAMENTALS OF THE GCT SYSTEM

GCT Structural Building System panels are prefabricated lightweight structural elements consisting of an expanded polystyrene (EPS) core sandwiched between two layers of galvanized steel welded wire mesh. A steel wire truss is pierced completely through the EPS core and welded to each of the outer layers of galvanized steel welded wire mesh. Where needed, additional deformed steel reinforcement bars are used. A high-strength mortar is sprayed onto each side of the panels at the jobsite to create monolithic wall, wall/slab and wall/roof concrete elements. Application equipment designed specifically for the application of mortar mixes is highly recommended.

The shape of the EPS core has been especially designed for the application of Carmelo structural mortar mix after on-site panel installation. The GCT Structural Building System provides a system of pre-manufactured modular panels allowing for faster assembly than conventional approaches. The GCT Structural Building System fulfills the required structural and load-bearing functions, and also has high thermal insulation values (R-value) and effective sound deadening capabilities (STC Ratings). The GCT Structural Building System is extremely versatile, allowing the designer to be very creative in the design of the building.

2.2. COMPOSITION OF THE GCT PANELS

The following are the basic components:

- A) **An expanded polystyrene (EPS) inner core**, which is nontoxic, non-hazardous, chemically inert and, with regard to fire exposure, is self-extinguishing. The EPS core is manufactured with varying density and thicknesses depending on panel type and application.
- B) **Electro-welded galvanized steel wire meshes** made of drawn steel wires placed on both sides of the polystyrene panel and connected by means of joints of the same material. The steel wire thickness varies according to panel type and mesh direction.
- C) **Structural Mortar**. Depending on panel type, Carmelo Structural Mortar Mix¹ is sprayed on the panel. Carmelo Structural Mortar Mix is a single component Portland cement based mortar containing additives for superior bonding strength. Depending on application, Carmelo Structural Mix may be sprayed or hand-troweled. The



product contains microspheres with pozzolanic action, making it less permeable and easy to place and finish. Packaged in 50 lb. bags, Carmelo Structural Mix is simple to use, requiring only the addition of water at the jobsite. Carmelo Structural Mix has a high degree of adhesion, shear and compression strength, which ensures excellent bonding with the GCT panel. The durability of structural reinforcements obtained with Structural Mortar Mix is enhanced by the product's high levels of resistance to sulfate attack and chloride ingress, which have a positive impact on the structural life of the system. This protection is advantageous for the conditions found in harsh coastal environments.

2.3. ADVANTAGES OF THE GCT STRUCTURAL BUILDING SYSTEM

The GCT Structural Building System provides these advantages:

- Versatility and diversity of panels to accommodate various architectural and design features.
- High thermal resistance (R-value). GCT panels having a finished thickness of 4" with 2" thick polystyrene core provides a similar R-value of that provided by an ordinary brick wall 25" thick.²
- High sound resistance (STC ratings).
- Easy to transport.
- Rapid assembly with little or no need for lifting equipment.
- High durability.
- Structural capacity to resist earthquake and hurricane forces.
- No skilled labor required.
- Lower costs and erection time.
- Lower foundation costs compared with traditional systems due to a significant reduction in weight.
- Integrates well with traditional systems.
- Fire-resistance ratings easily accomplished by varying the thickness of the applied structural mortar.
- Straightforward, rapid installation of the plumbing, heating, electric, telephone systems, etc.
- Easy to customize panel length and thickness.
- Solid structural panel-to-panel connection.
- Panel surface and GCT mortar machines are specially designed for a smooth mortar spraying.
- GCT connection meshes also include 90° connection flanges for corners and U type meshes for edges.
- The expanded polystyrene core works as a barrier to thermal bridging.
- Environmentally friendly, from fabrication to final construction.

¹ Carmelo Structural Mortar Mix is the preferred Structural Mortar developed specifically for the GCT Building System. However, a locally obtained structural mortar is allowed provided all of the specifications are equal to or better than the Carmelo Structural Mortar Mix.

² National Research Council of Canada, Division of Building Research, Technical Note 380.

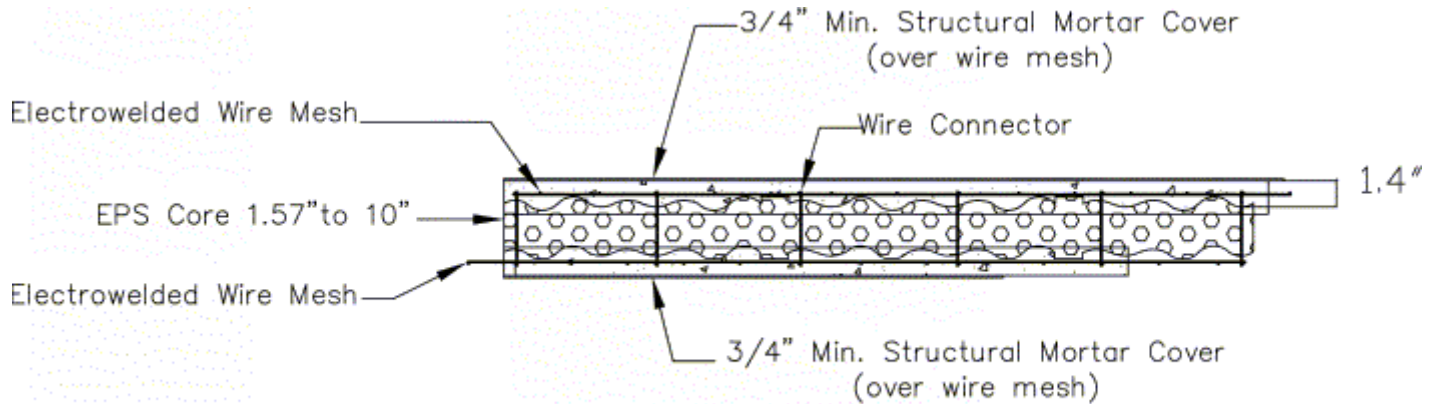
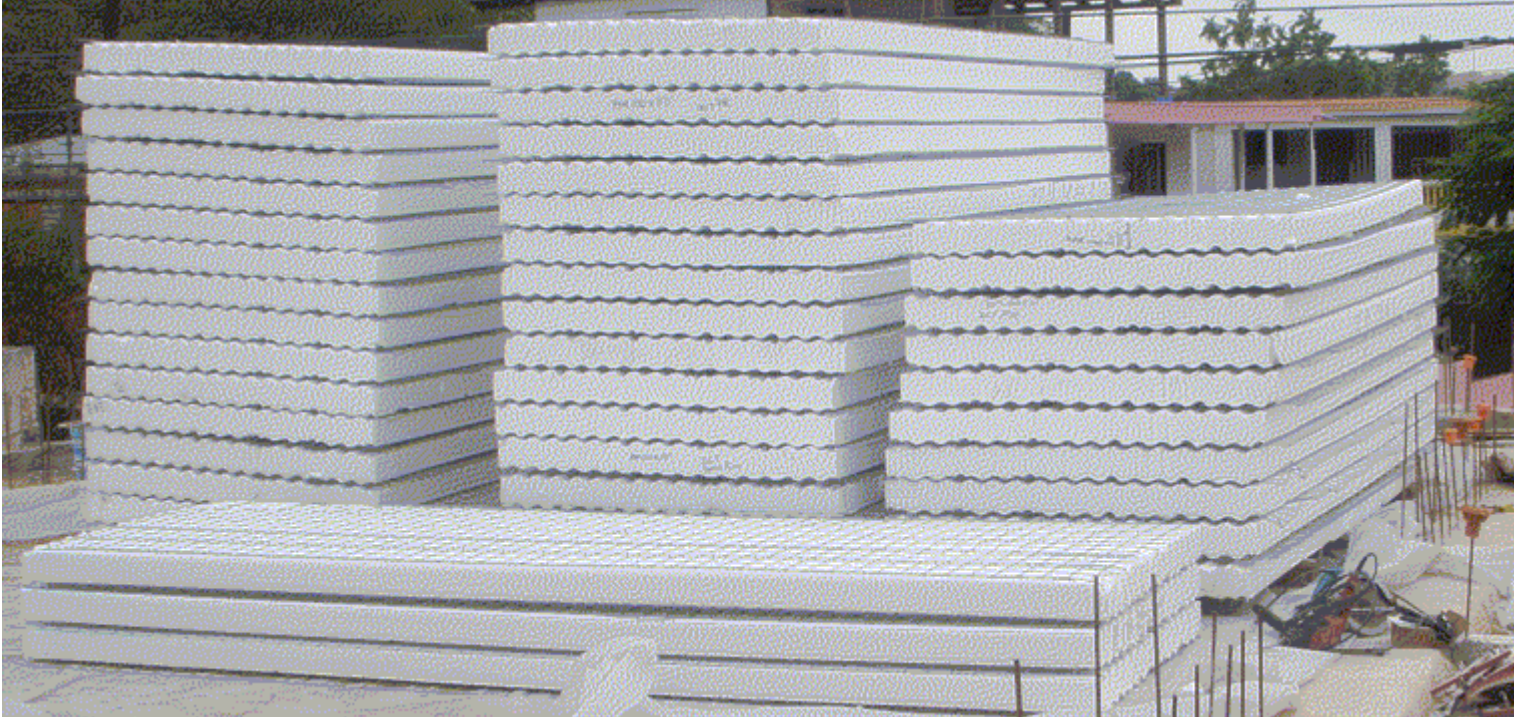

PSM Wall Section

3.0 CLASSIFICATION OF THE GCT PRODUCTS

The GCT Structural Building System panels and complementary products are described below. The panel thickness and length can be customized, according to project requirements and customer demands. The thickness of a panel is determined primarily by the required structural behavior. Additionally, insulation (R-value) requirements may dictate a thicker panel.

3.1 GCT STRUCTURAL BUILDING SYSTEM PANEL TYPES

There is a variety of GCT Structural Building System panels and accessories to meet the needs of each project. This section describes each of these items and their use. Custom products are

also available upon request for specialized situations. Call us at 866-936-6416 or contact us online at gulfconcretechnology.com for all of your custom product needs.

3.2 GCT SINGLE PANEL PSM

The single panel (PSM) is generally used for buildings of no more than four stories. The panels may be used for wall applications as well as for roof and floor assemblies. For residential and light commercial applications, this is the primary panel used in the GCT Building System. When combined with other PSM, PSM HP or PSG floor and roof panels, the GCT Structural Building System provides a very strong and energy efficient structure.

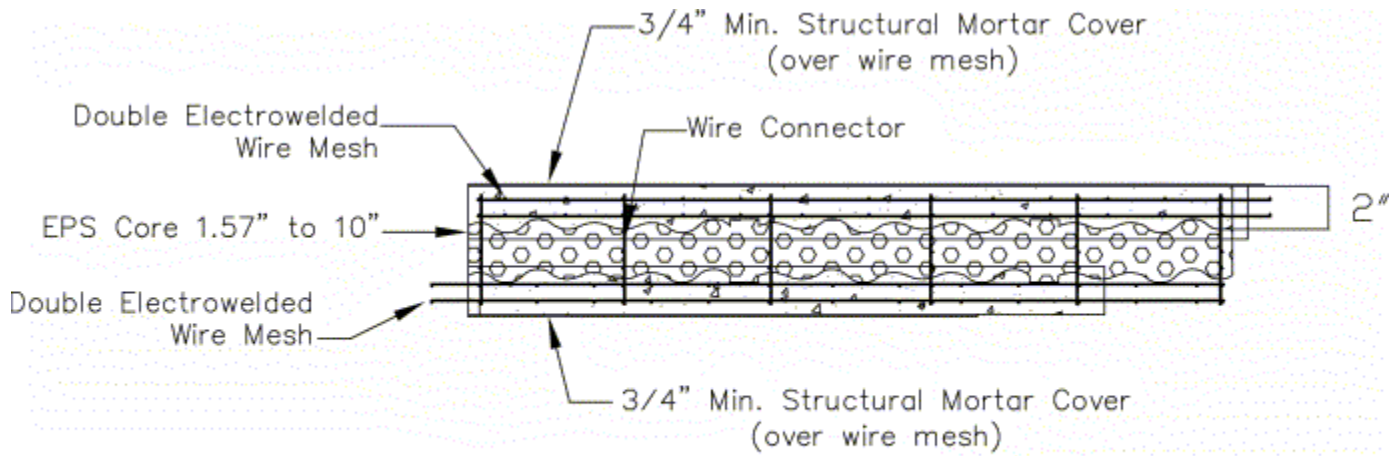
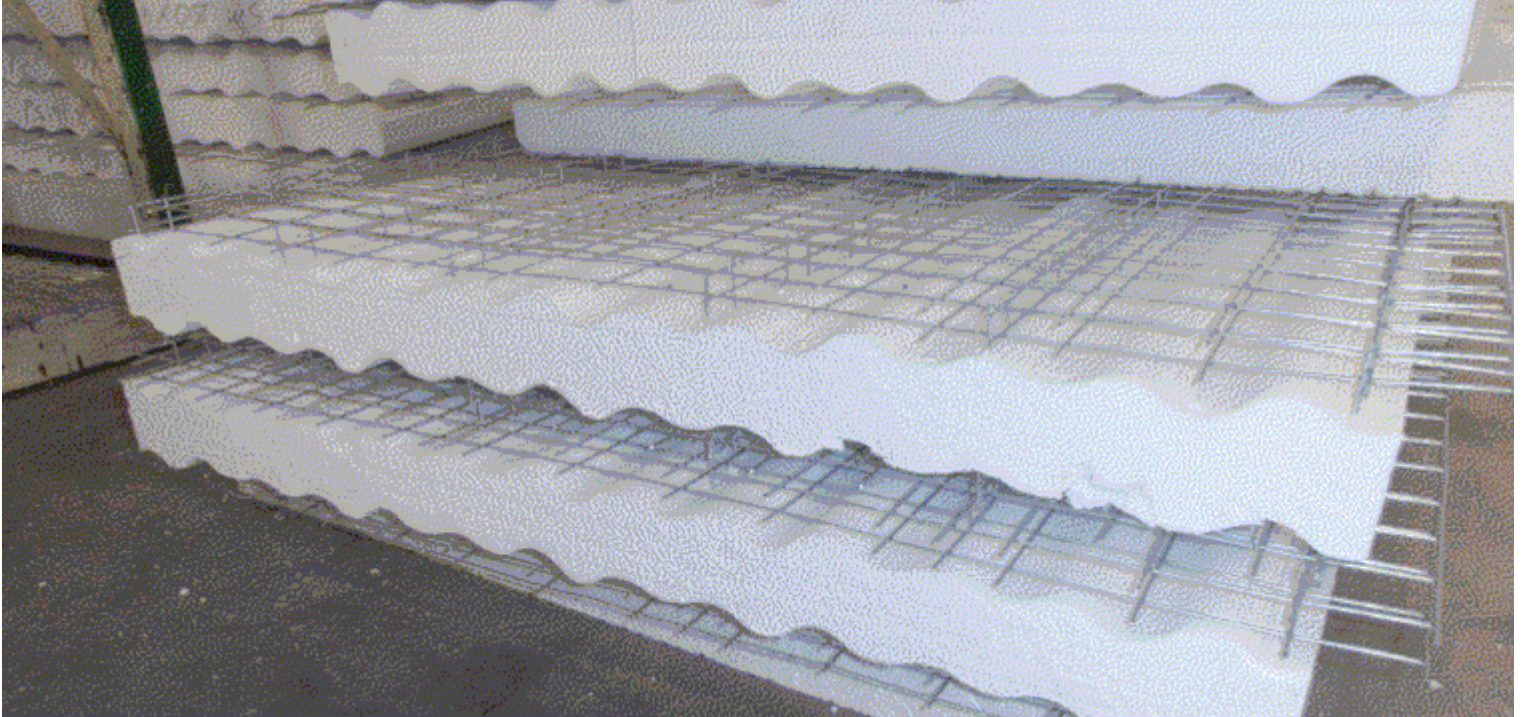

PSM HP Wall Section

3.3 GCT SINGLE PANEL PSM HP

The high performance single panel (PSM HP) is generally used where increased strength is needed or desired. Like the PSM panels, PSM HP panels may be used for wall applications as well as for roof and floor assemblies. When combined with other PSM or PSG floor and roof panels, the PSM HP panels give the building designer the ability to be more creative and versatile in their design.

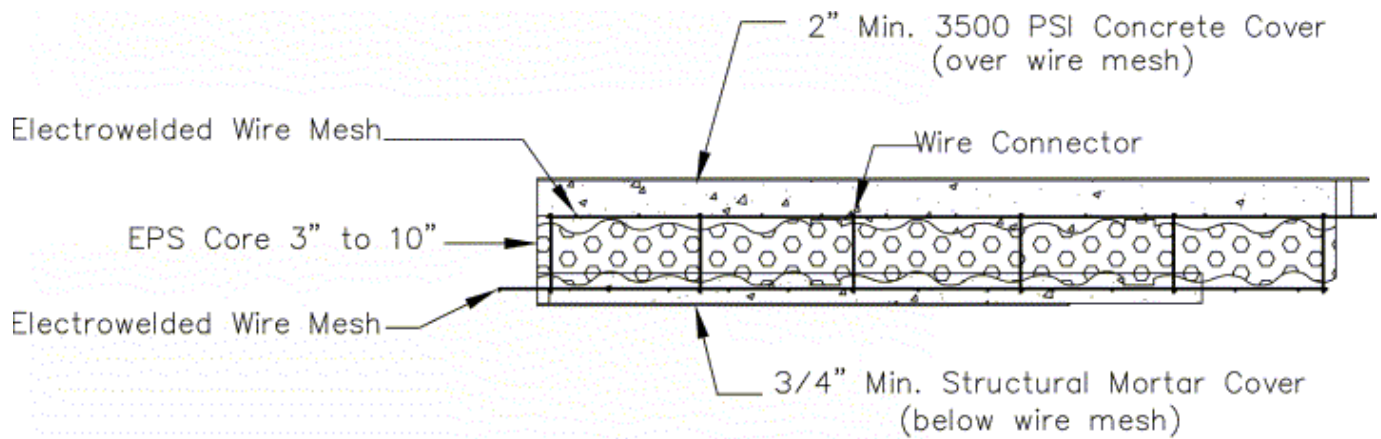

PSM Slab Section

3.4 GCT PSM SLAB

The PSM SLAB and PSM HP SLAB are used for roof and floor assemblies. For residential and light commercial applications, this is the primary panel used in the GCT Building System for floor and roof applications. Depending on the thickness of the panel used, this solution is applicable for floor slabs having spans up to 20'. Where longer spans or heavier loads are desired, the PSG floor and roof panels offer expanded capabilities.

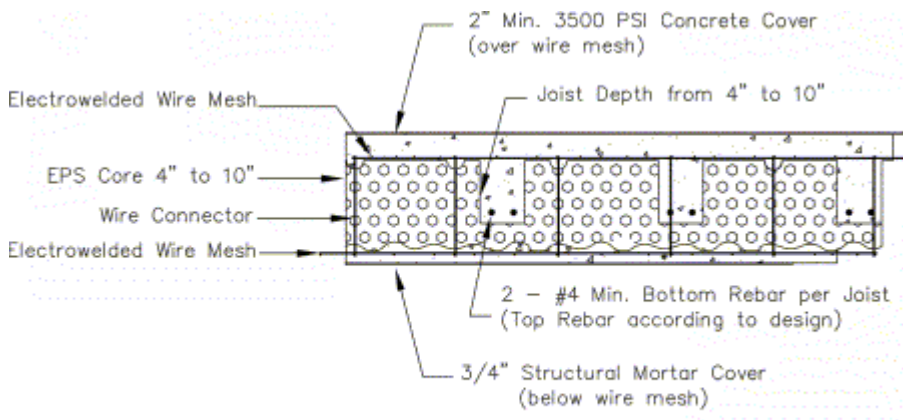
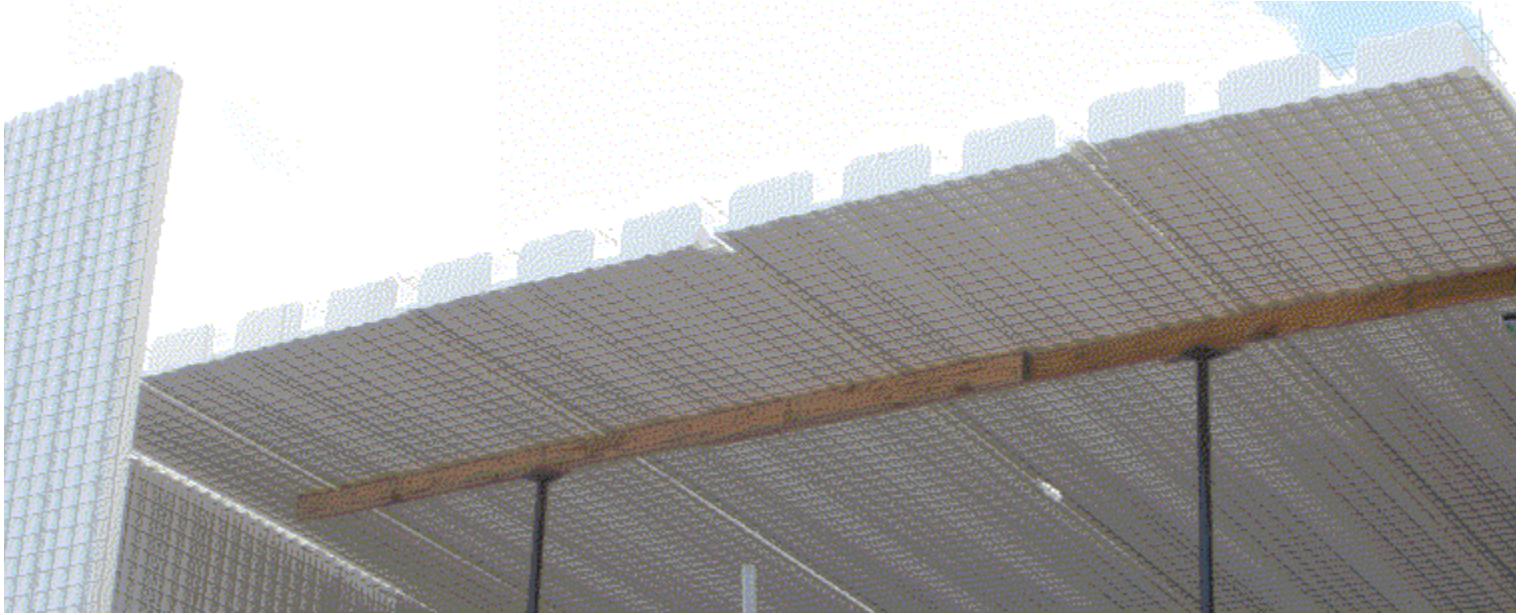

PSG3 Slab Section

3.5 GCT FLOOR PSG PANEL

This type of panel is used for intermediate floor and roof systems and is strengthened in the joists with reinforced concrete beams cast on site. Reinforcement of the panel is integrated during the panel assembly by adding reinforcing bars (following the structural design) inside the joists. This solution is applicable floor slabs having spans up to 32'.

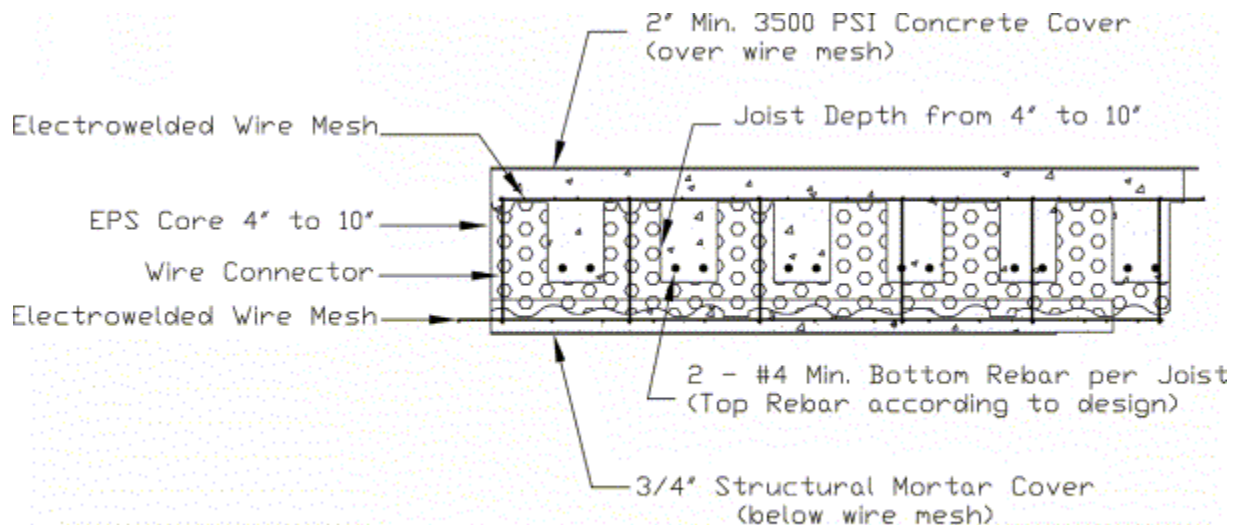

PSG6 Slab Section

3.6 GCT STAIRCASE PANEL

This panel consists of an expanded polystyrene block shaped according to the specific dimensions of the project. The EPS is reinforced with meshwork on the surfaces and rebar in the ribs that extend through the panel. Reinforced on the inside cavities and finished with casting on site, it is used for the construction of staircases up to a maximum span of 20' having a live load of 80 lb./ft² (400 Kg/m²). If necessary, greater loads may be obtained through specially designed reinforcement.

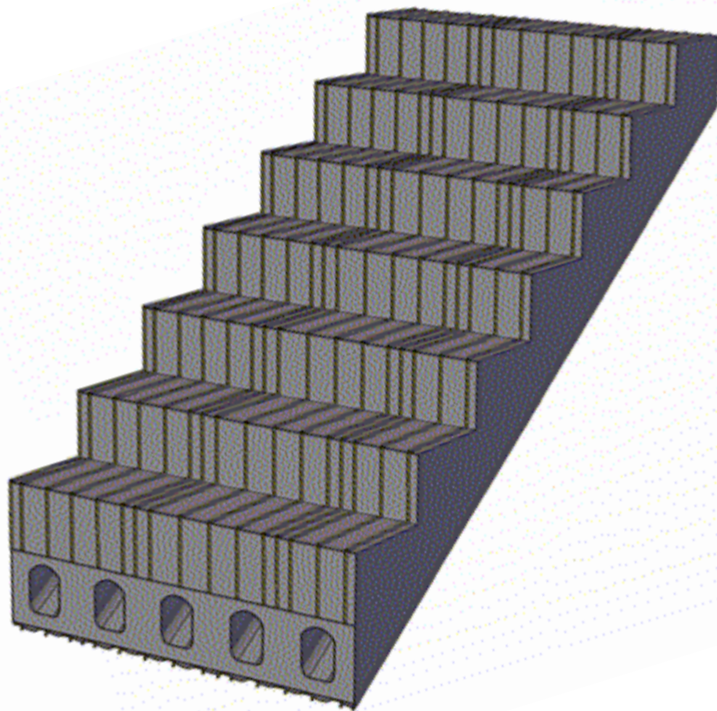
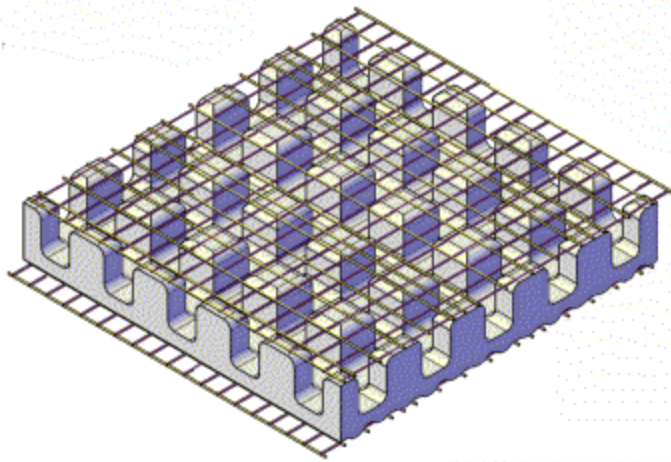

3.7 REINFORCING MESHWORK

Designed with galvanized steel wire, the reinforcing meshwork is used to reinforce openings and joints between panels to provide continuity to the structural mesh. "C" clips or hog rings are used to attach the reinforcing meshwork to the meshwork on the panels. Each reinforcing meshwork comes in a standard 4' length. The standard reinforcing meshwork that are provided with the GCT Structural Building System are shown below:

ANGULAR MESHWORK RG1

(INTERNAL AND EXTERNAL CORNER MESH):

- Reinforces angle-connections. Typically used at all intersecting walls and at wall-to-roof or wall-to-floor intersections.

FLAT MESHWORK RG2:

- Reinforces the corners of openings (placed at 45° angle to the corner).
- Restores meshwork that had been previously cut.
- Is suitable for any joints between panels.

“U” SHAPED MESHWORK RG3:

- Restores the continuity of the panels along the perimeter of openings like doors and windows. Can also be used to anchor GCT Structural Building System panels to the foundation in lieu of rebar.

REINFORCING MESHWORK:

- Restores the mesh work of bent panels.
- Restores the meshwork of panels cut due to:
 - Non-standard sizes (overhanging mesh cut off)
 - Installation of piping

- Adds additional reinforcement for the installation of heavy objects such as kitchen cabinets.
- Adds additional strength where needed to meet specific loading conditions.

The GCT Structural Building System is shown to be code compliant through several Technical Evaluation Reports that are available upon request at sbcri.info/productapproval/gct.php. Buildings designed using the GCT Structural Building System shall be designed by a Registered Design Professional and the construction documents shall be sealed in accordance with that design.

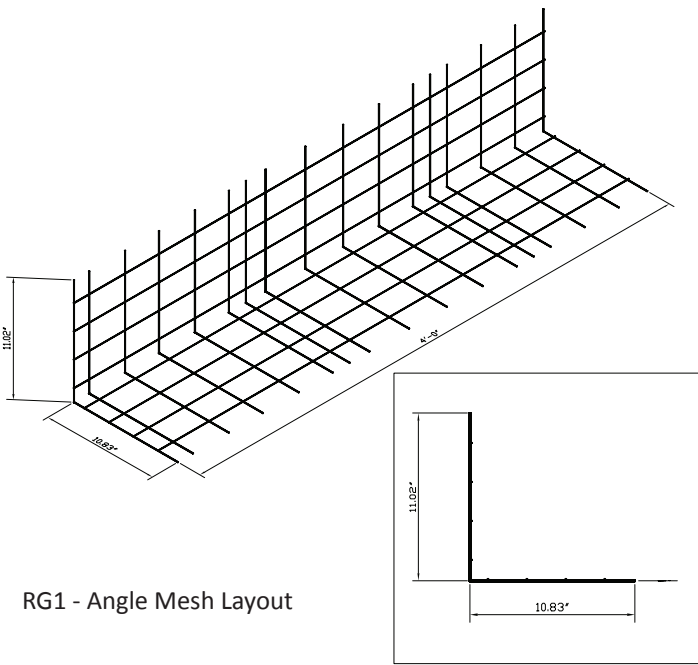

RG1 - Angle Mesh Layout

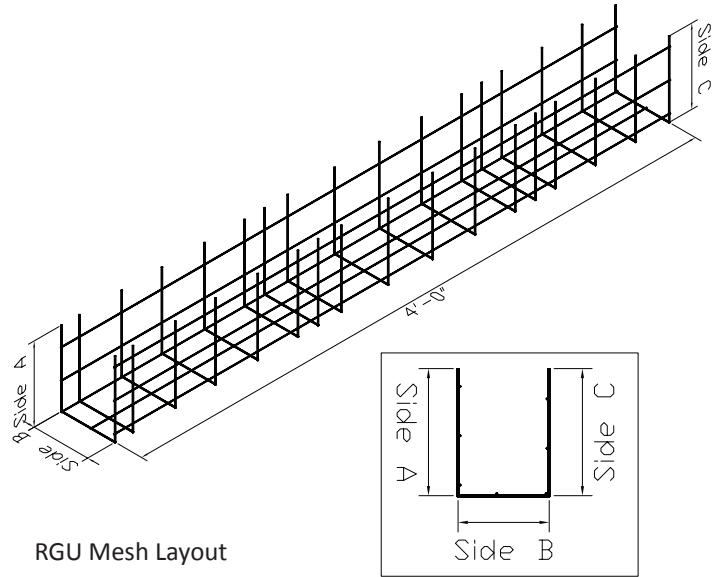

RGU Mesh Layout

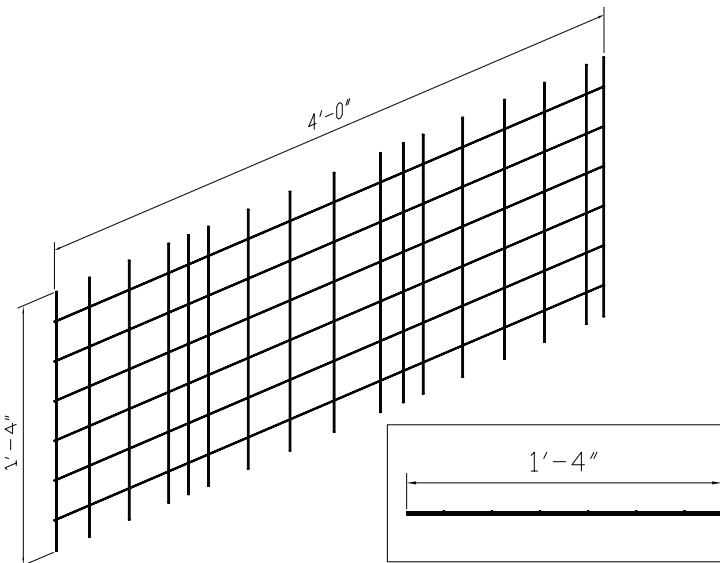

RG2 - Flat Mesh Layout

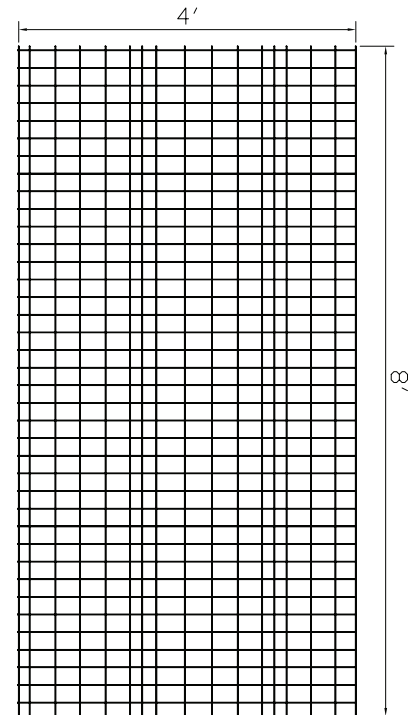

4x8 Flat Meshwork

GCT RENDER MORTAR OR CEMENT PLASTER APPLICATION MACHINES FOR WALLS AND CEILINGS



M-TEC DUO MIX PLUS

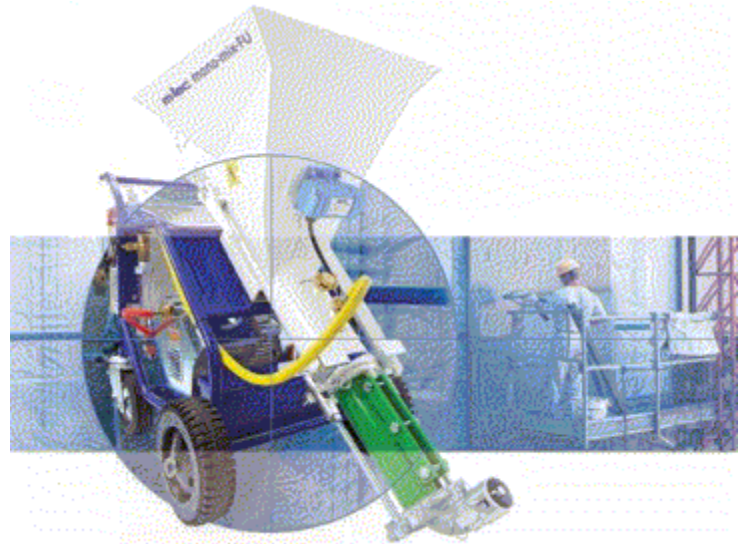

M-TEC MONO MIX

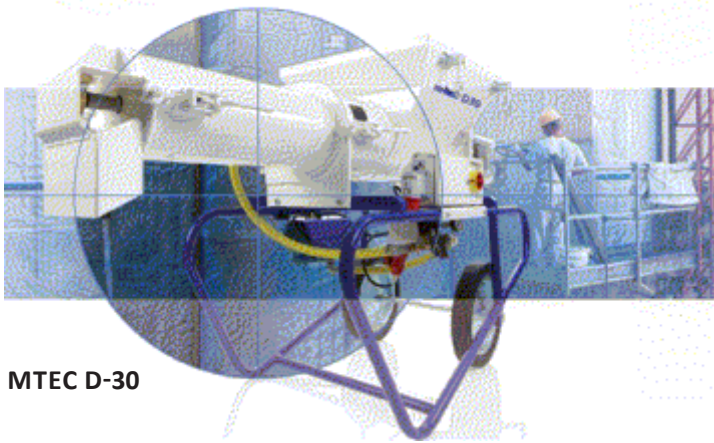

MTEC D-30



M-TEC M-300



MTEC M300+FC300

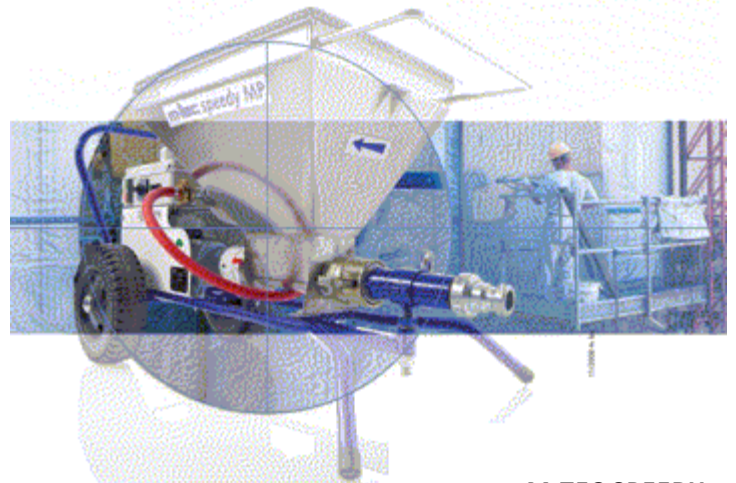

M-TEC SPEEDY

INSTALLATION GUIDE



INTRODUCTION

The GCT Structural Building System Technical Manual provides guidelines and direction to help the builder in the process of installing the Gulf Concrete Technology (GCT) Building System, in accordance with a design provided by a Registered Design Professional.

The GCT Structural Building System is shown to be code compliant through several Technical Evaluation Reports that are available upon request at sbcri.info/productapproval/gct.php. Buildings designed using the GCT Structural Building System shall be designed by a Registered Design Professional and the construction documents shall be sealed in accordance with that design.

The purpose of this guide is to aid the contractor and installer with the proper procedures for receiving, unloading, storing, handling, identifying, installing, finishing and bracing the GCT Structural Building System panels.

This document contains important safety information. Jobsites are inherently dangerous and this document provides the contractor and installer with important information that will help avoid jobsite injuries. Disregarding or ignoring these handling, installing and bracing safety recommendations is the major cause of GCT Structural Building System erection/installation accidents. The erection/installation of GCT Structural Building System requires careful planning and communication between the contractor involved with the erection/installation, and the installation crew. It is strongly recommended that all onsite individuals involved in the lifting, installing and bracing operations hold a pre-construction meeting to review the provisions of the GCT Installation Manual, the GCT Structural Building System assembly layout, the GCT Structural Building System panel documentation, the Construction Documents, OSHA jobsite lifting and fall protection requirements, and any other requirements applicable to the jobsite.

It is recommended that this review process be followed before any GCT Structural Building System handling operations are performed. It is also recommended that this meeting be held before each new project and be repeated for any individuals newly assigned to the project. Proper bracing/shoring of GCT Structural Building System panels requires an understanding of bracing/shoring equipment and techniques and their limitations. All bracing and shoring should be designed by a Registered Design Professional. This installation manual is for general guidance only and cannot address all possible jobsite conditions. The Contractor involved with the erection/installation shall be familiar with general bracing/shoring concepts as discussed in this manual. It is not intended that these recommendations be interpreted as superior to the Building\Designer's design specification for handling, installing and bracing the GCT Structural Building System and it does not preclude the use of other equivalent methods

for bracing and providing stability for the walls, columns, floors, roofs and all the interrelated GCT Structural Building System components as determined by the Contractor.

WARNING

The handling, storing, installing and bracing of the GCT Structural Building System requires specialized training, clearly implemented procedures, and careful planning and communication among the Contractor and all installation crews. Property damage and/or serious bodily injury are possible results when handling and installing GCT Structural Building System components without appropriate training, planning and communication.

Prior to GCT Structural Building System installation, it is recommended that the documents be examined and disseminated to all appropriate personnel. In addition to proper training and a clear understanding of the installation plan, any applicable fall protection requirements and the intended bracing requirements shall be understood.

Examine the jobsite and specifically the foundation for suitability in providing the support needed for the GCT Structural Building System and begin installation only after any unsatisfactory conditions have been corrected. GCT Structural Building System components may be cut, modified and repaired onsite with the approval of the RDP. Report any damage before installation and obtain the appropriate repair prior to installation.

The information in this booklet is offered as a minimum guideline only. Nothing contained in this manual shall be construed in any manner as expanding the scope of responsibility of or imposing any additional liabilities on GCT.

Every project has different site conditions that can have a specific effect on the erection process. Before the first GCT Structural Building System panel is erected, every individual involved shall understand the plan for setting the panels and the bracing/shoring requirements for a safe, efficient and accident-free jobsite.

PRECAUTIONARY NOTE TO USERS OF THE GCT STRUCTURAL BUILDING SYSTEM INSTALLATION MANUAL

This GCT Structural Building System Installation Manual may be edited, changed, revised or withdrawn at any time. Users of this guide are advised to ensure that this edition contains the most current information available. Use only the latest edition. Additionally, errata and updates are published periodically and are available at www.gulfconcretechnology.com.

CHECKLIST FOR HANDLING & INSTALLING THE GCT BUILDING SYSTEM

Review all the information provided in the JOBSITE PACKAGE to ensure compliance with industry recommendations.

Property damage, serious bodily injury and/or death are possible when handling and installing the GCT Structural Building System without following the recommendations presented in the JOBSITE PACKAGE. This is particularly true during the placement of concrete. Use the following checklist when handling and erecting the GCT Building System:

- Inspect the GCT Structural Building System at the time of delivery and after installation for:
 - (1) Conformance with the GCT Structural Building System component and assembly drawings.
 - (2) Dislodged/missing wire meshwork reinforcement.
 - (3) Damaged or broken wires in the reinforcing meshwork.
 - (4) Broken or damaged EPS Cores.
 - (5) Any other damage that may impair the structural integrity of the GCT Structural Building System

Notify GCT if GCT Structural Building System component repairs are needed. After installation, if damage to the GCT Structural Building System components is discovered that could weaken them, provide temporary bracing and shoring to prevent further damage. Make sure the area remains clear of plumbing, electrical, mechanical runs, etc. until the required repairs have been properly completed.

DO NOT perform a repair until you have received instructions from the Registered Design Professional.

- Protect GCT Structural Building System components from weather, corrosion, lateral bending, damage and deterioration when stored at the jobsite. When the GCT Structural Building System components are stored at the site, use blocking, stringers, pallets, platforms or other means of support to keep the components off of the ground to avoid damage and/or the collection of dirt and moisture, which can hinder the adhesion of the structural mortar.
- Carefully review the GCT panel drawings, the Assembly Layout and all JOBSITE PACKAGE documents prior to handling and installing the GCT Building System.
- Examine the jobsite foundation provided for the GCT Structural Building System panels and related installation conditions. Begin installing the GCT Structural Building System only after any unsatisfactory conditions have been corrected.

- Review the GCT Structural Building System Jobsite Package and installation manual to determine the proper attachment methods to be used at the jobsite.
- Install bracing and shoring in accordance with the guidelines in the JOBSITE PACKAGE to prevent the GCT Structural Building System from collapsing during installation. Erect GCT Structural Building System components using the methods indicated, keeping the wall panels vertical and properly braced. Anchor GCT Structural Building System components securely at bearing locations.
- Refer to the Construction Documents for any required reinforcing locations. Reinforcement shall be correctly installed and attached.
- Comply with the Owner's, or the Owner's retained Registered Design Professional's building stability bracing, anchorage, connections and field assembly requirements. This information is typically provided in the Construction Documents.
- Install structural mortar as soon as possible. The strength of the GCT Structural Building System is reliant on proper installation of the mortar and concrete.
- During construction, distribute material and equipment loads on the GCT Structural Building System to stay within the limits of the carrying capacity for each component. Make sure the GCT Structural Building System is adequately braced/shored BEFORE placing any Construction Loads on them. Only install HVAC units, fire sprinklers, etc. on components if they have been designed to accommodate these specific loads and the mortar/concrete has sufficiently cured. Review the component design drawings for the assumed loads and locations.

NOTE: Temporarily braced/shored structures are NOT suitable for use or occupancy. Restrict access to construction personnel only.

GCT BUILDING SYSTEM: OUTLINE OF CONSTRUCTION

Once the building has been designed, and physical construction is ready to commence, the following outline provides a guideline for the steps involved in the construction process:

1. Lay foundations with steel rebar or U shaped meshwork designed for the job. Proper placement of the reinforcing is critical at this stage to ensure trouble free alignment of the panels.
2. Receive and store panels on site.
3. Identify the structural elements and verify all types and quantities.
4. Select the structural elements.
5. Assemble the wall panels.
6. Vertically erect wall panels with the help of guides and braces. These are necessary to maintain proper alignment and stability during the construction process.
7. Place all meshwork and reinforcement rods.
8. Build support frames for doors and window openings.
9. Assemble floor panels and install shoring.
10. Trace and install mechanical systems (plumbing, electrical, etc.).
11. Apply first coat of structural mortar (scratch coat) on the wall.
12. When sufficiently cured, the wall bracing can be removed and the second coat of mortar can be applied.
13. Spray the scratch coat of mortar on the lower face of slab panels.
14. When the lower surface has sufficiently cured, the concrete on the upper surface of floor panels may be poured.
15. Completely remove the shoring (28 days after pouring the floor).
16. Apply finish coat of mortar on ceiling.
17. After proper curing of structural mortar, cement plaster finishes may be applied.

DETAILS OF THE INSTALLATION PROCESS:

RECEIVING:

- Checking the load:
 - Prior to unloading, the delivery of the GCT components should be inspected for any visible damage. Any damage found during the inspection should be noted and reported to GCT. If necessary, GCT will provide a repair for or replacement of the damaged product.
 - Product quantities. The delivery should be checked upon receipt for the proper types and quantities of GCT Structural Building System components and accessories.

UNLOADING

One of the advantages of the GCT Structural Building System is that the individual components are lightweight and can be easily maneuvered manually. Unloading equipment is not required, but may be desired for greater efficiency in unloading or moving components about the jobsite.

- Beginning with the unloading process, and throughout all phases of construction, exercise care to avoid excessive lateral bending of components, as this can cause damage to the EPS core or wire reinforcing mesh.
- Limit exposure of the GCT Structural Building System Components to the elements (see section on storage).

When using lifting equipment to unload GCT Structural Building System components:

- Make sure components in a bundle are securely connected together prior to moving. Components may be bundled together during shipment but the banding may have been damaged or dislodged during transit. Where necessary for safe lifting, additional banding may be added prior to unloading.
- Do not lift bundles by the banding. Banding is intended to hold bundles together during transit and is not designed to hold the weight of the bundles.
- Proper banding and a smooth, level surface allow for unloading of GCT component bundles without damage. Components should be unloaded as close to the building site as possible to minimize handling.
- Use care to not damage the components with the forks. Use pallets where possible.
- Do not break banding until erection/installation begins.
- Do not drag or push components along ground.
- Do not store components on uneven ground.

When unloading GCT Structural Building System components without lifting equipment:

- Components may have been banded together for shipping. Carefully cut and remove banding. Banding is under tension and cutting the bands can cause unexpected movement of the banding or components so precautions should be taken to avoid injury. Use of gloves and safety glasses is strongly recommended.
- A smooth and level surface allow for unloading of GCT components without damage. Components should be unloaded as close to final location in the building as possible to minimize handling.
- Components should be placed on a level surface, off the ground. Use of stickers or pallets is recommended.
- Carefully unload each component by manually transferring the components from the truck to the storage area.
- Do not break banding until unloading begins. Be careful when cutting banding as product may shift when the banding is released.
- Do not drag or push components along ground.
- Do not store components on uneven ground.

CAUTION: Exercise care when removing banding to avoid damaging components and prevent personal injury. Gloves and safety glasses should be worn.

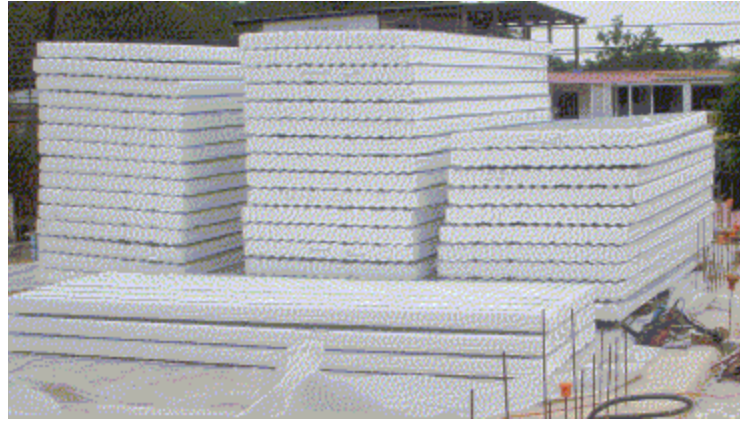

STORAGE

An area, preferably covered, shall be designated for storing the panels delivered to the jobsite from the GCT plant.

The panels must be placed carefully on a flat, rigid surface, so they can be stacked with the panels lying flat.

GCT panels should not be placed directly on the ground without a means of keeping the panels clean and free from dirt and debris, which could lead to problems with mortar adhesion.

GCT panels should be protected from the rain or other wetting for the same reason.

Long-term exposure to ultraviolet light (sunlight) can cause yellowing and a slight embrittlement of the Expanded Polystyrene (EPS) core surface. As such, when stored outdoors, the GCT panels should be covered with light colored tarpaulins. If tarpaulins or other protective covers are used, the ends shall be left open for ventilation.

GCT panels should be tied down with restraints of sufficient strength to prevent accidental movement by the wind.

IDENTIFYING THE PANELS

Panels that are the standard 48" in width are marked to designate the length of the panel. Panels that are of non-standard width and that are to be cut in the field from standard width panels are marked accordingly. The Assembly layout provides the installer with a depiction of the intended location of each of the panels delivered to the jobsite. Where multiple panels are to be field cut on at the jobsite from one larger panel, they are shown on the panel layout as well. The layout of the floor or roof panels are also shown when applicable (see Figure 1 at left).

STAGING

When preparing the panels for installation, panels should be placed near the final installed location for greater efficiency during the installation procedures.

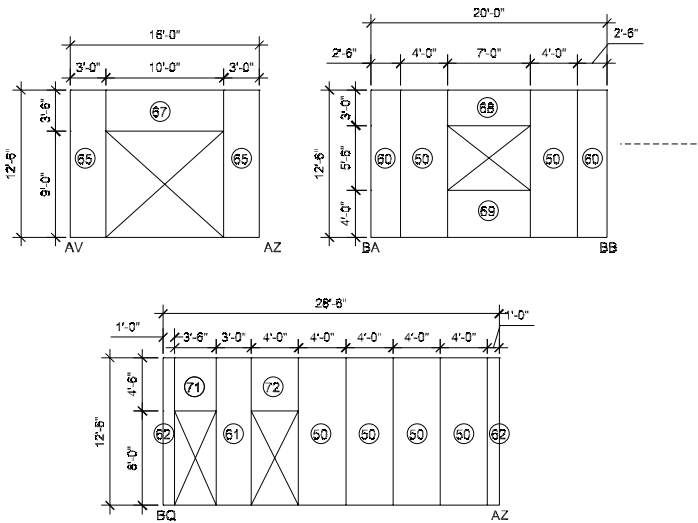

Typical Panel Layout

Figure 1: Example of assembly layout drawing.



INSTALLATION

SITE PREPARATION

One of the keys to a safe and efficient jobsite is proper attention to preparing the site for construction. When the site is excavated, care should be taken to not only prepare the building site, but also the area around the building site. The working area around the building should be as level as conditions allow and free of clutter. Wide open and level ground around the building allow for more efficient movement of workers and materials around the site and reduces the risk of injury. In addition, preparing areas for storing and staging materials should be considered that are also level and free of congestion. Storage and staging areas should be close enough to the building to avoid excessive handling, yet far enough away to allow for the free movement of workers around the building.

FOOTINGS

A structure built with the GCT Structural Building System starts with the footings. The footings may be made in any manner as allowed by the applicable building code (slab on grade, turned

down slabs, stem walls, foundation footings, etc.) provided the resulting foundation is level, provides a continuous bearing for the GCT panels, and is capable of transmitting all imposed loads to the supporting soil. Such foundations should be designed in accordance with the applicable building code, keeping in mind the geo-mechanical characteristics of the soil.

The footings serve as a base for the rebar or u-shaped mesh used to anchor the GCT Structural Building System panels. The dimensions, quantity and length of the rebar depend on the resistance required at the base of the panel (e.g., a typical installation might consist of #3 or #4 rebar placed at 8" o.c., extending 18" above the footing and staggered on each side of the wall). Consult the construction documents for the project specific anchorage requirements. Once the footings are in place and sufficiently cured along with the required anchorage, assembly of the PSM wall panels may begin.

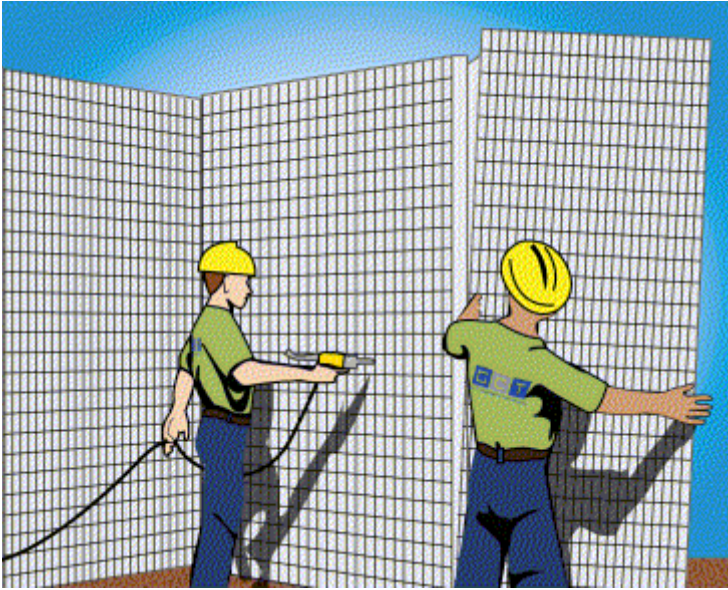

GCT STRUCTURAL BUILDING SYSTEM ASSEMBLY

This section explains the utilization of GCT Structural Building System in the erection of single panel walls (PSM or PSM HP) and floors (PSM or PSG).

SELECTING THE PANELS

To assist with panel selection and placement, all panels are marked with the heights that comply with the assembly layout. The panels that are marked only with height are standard height and are installed as is. Additionally, standard height panels may be shipped that are intended to be cut to size on site. If the panel sizes are to be field cut, or multiple panels are to be cut from a larger panel, the layout shows a panel mark and provides the layout of how the smaller panels are cut from the larger one. (See Figure 1).



Photo 1: Connection of wire meshwork to foundation rebar anchorage using wire ties.

ASSEMBLING THE WALL PANELS

Begin by placing chalk lines on the footings to mark the desired location of the walls keeping in mind the thickness of the mortar that will be applied to the walls. This will help in the placement of the walls by providing a reference line for the location of the bottom of the panels. Beginning at one corner of the building, place GCT panels in accordance with the assembly layout.

GCT panels are anchored to the foundation by connecting the wire mesh on the panels to the rebar or U-mesh in the foundation using pliers and steel wire ties. (See Photo 1 and Figure 2 and 2a). It is essential that the EPS foam is removed from around the rebar to allow it to be encapsulated by the mortar. Using a heat gun is recommended. Note also that connections for interior walls are similar.

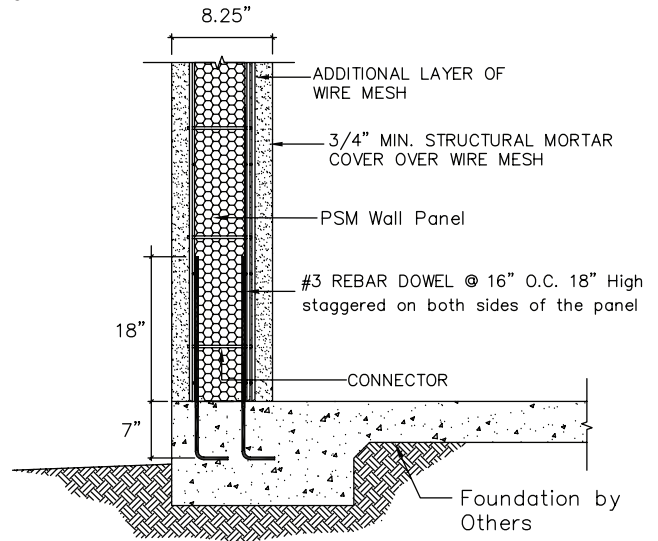

Figure 2: Example of GCT Panel Connection at Exterior Turned Down Slab Footing using rebar anchorage.

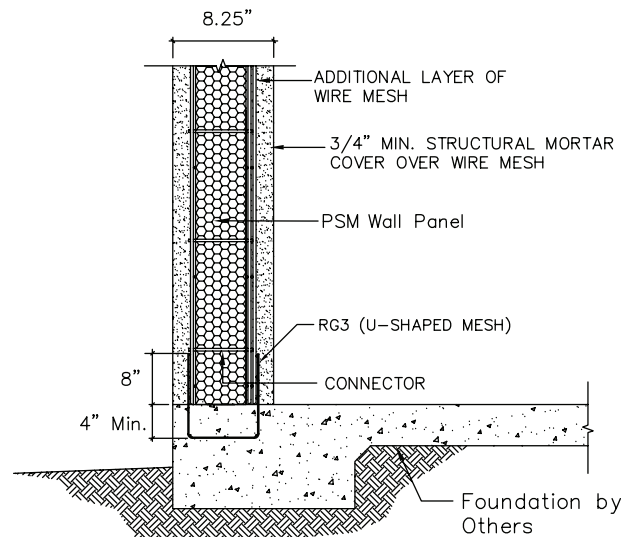

Figure 2a: Example of GCT Panel Connection at Exterior Turned Down Slab Footing using U-shaped wire mesh anchorage.

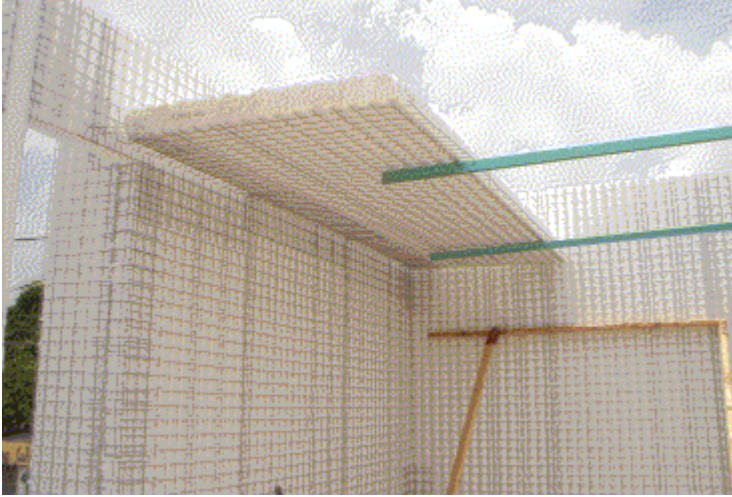

Photo 2: Installation of PSM panels.

In order to guarantee continuity of the panels along the wall, a mesh wing is provided along one vertical edge of each panel. This mesh wing extends beyond the edge panel and overlaps the mesh on the adjacent panel (see Photo 2 and Figure 3). Connection of adjacent panels is done by attaching the overlapping meshwork to each other. This can be carried out using pneumatic tools that use “C” clips or hog rings, or by manually binding them. The connections are made every 10" (one connection at every fourth horizontal wire).

Set the first panel such that the overlapping mesh overhang is on the exterior side of the wall. The following panel is then simply placed (from the interior) by tilting it up and against the overlapping mesh from the proceeding panel. Proceed by setting panels and connecting them to the footing (rebar anchorage) and the adjacent panel, one panel at a time.

It is recommended that the installers complete one room at a time before continuing to the next. Completing one room at a time provides additional rigidity to the system during construction due to the interconnection of wall assemblies perpendicular to each other.

At this stage, no gaps should be left between the joints of polystyrene cores. Special attention should be paid to the panel



Photo 3: Manual clamping tool for connection of wire mesh.



Photo 4: Pneumatic clamping tool.

installation to ensure that the panels are plumb and in good alignment with each other. This will ensure that the panels perform as expected both from a strength perspective and a thermal resistance perspective. Should gaps in the EPS occur between cut panels, or other locations where the EPS has been removed, the gaps should be filled with spray foam to protect the integrity of the insulating properties.

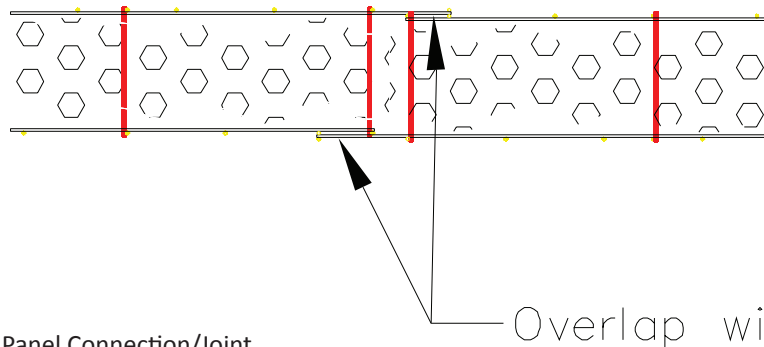

Figure 3: Panel to Panel Connection/Joint

Overlap wire mesh)

Proper assembly requires periodic checking to ensure walls are level, plumb and straight. To hold wall panels in the correct location, walls shall be properly braced. This can be accomplished by connections to perpendicular walls or diagonal bracing. Use of aluminum box profiles along the top of the wall (13' in length) and adjustable diagonal braces anchored firmly into the ground (see Figure 4) are recommended. Generally, for walls less than 14' in height, one aluminum box placed near the panel top plates with diagonal braces placed every 10' is sufficient. GCT recommends placing the diagonal braces on one side of the wall to keep the opposite side completely clear of obstructions. This allows for easier application of the structural mortar once all connections and reinforcements are installed. For walls 14' and taller, use one row of bracing with diagonals for each 7-8 feet of wall height.

During assembly, it is important to be aware of the location of the openings in accordance with the assembly layout. Openings for doors and balconies must be placed in accordance with the design. Openings less than 4' in width can be cut in after assembling panels by using cutting instruments, such as saws, shears and even knives and pliers. Any modification of the openings from the construction documents or the need to create others, requires approval from the Registered Design Professional.

With regard to windows and door openings, the panel section should be oriented horizontally to accommodate headers. Below windows, the panel section can be oriented in either direction.

Rough opening edges should allow for 1-½" of mortar to be applied surrounding them, with U mesh placed centrally in the 1-½" space, allowing around ¾" space from the EPS to the mesh and ¾" from mesh to mortar finish. This will apply also to wall ends and any other edges or terminations.

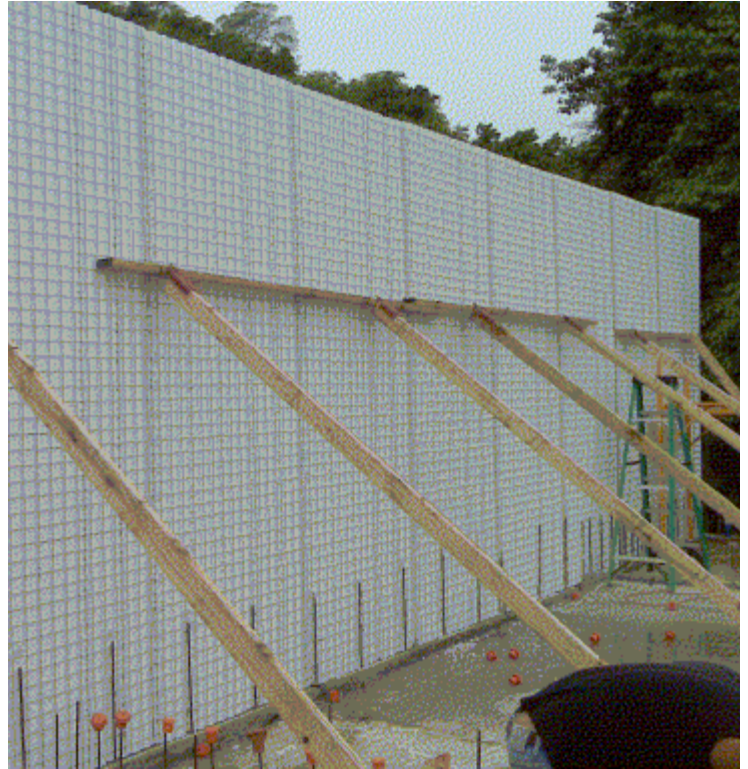

Photo 5: Temporary diagonal wall bracing.

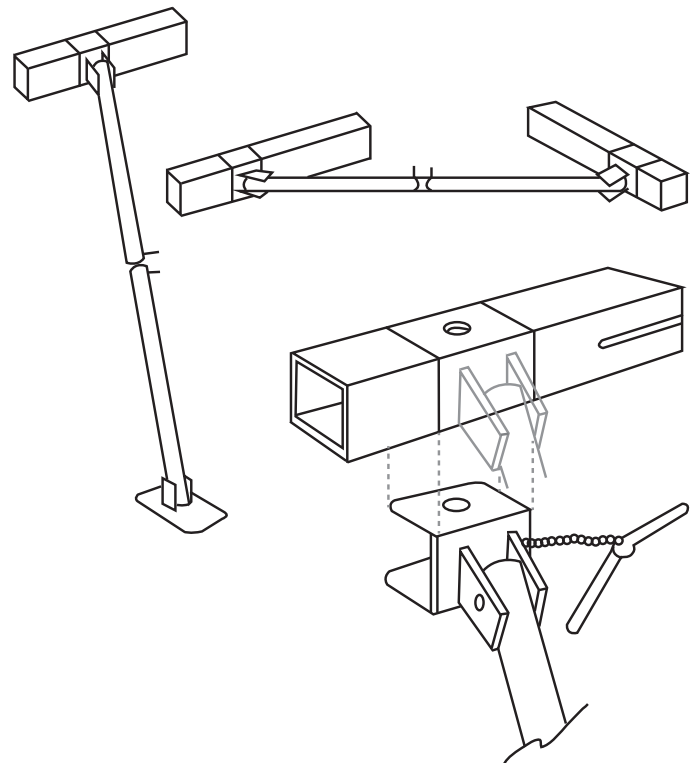

Figure 5: Aluminum box profile with diagonal bracing.

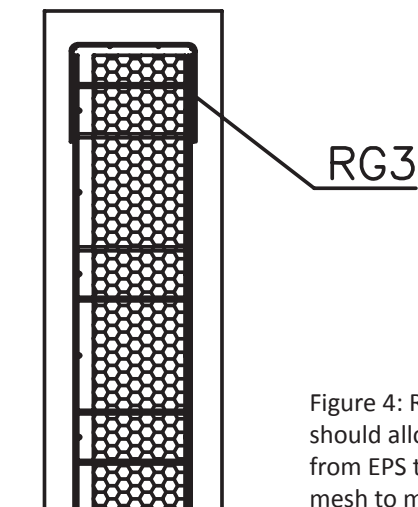

Figure 4: Rough opening edges should allow ¾" on either side, from EPS to the mesh and from mesh to mortar finish.

GCT PANELS USED AS PARTITION WALLS

Prior to installation, trace the outlines of the interior partitions on the floor, ceiling and walls by snapping chalk lines. Take particular care with the horizontal and vertical lines to ensure they are plumb and level (see Figure 5).

Once the lines are traced, drill holes for the placement of anchorage at the base of the walls per the construction documents. Spacing and size of anchorage will vary depending on the purpose of the wall (i.e., load bearing, non-load bearing or part of the lateral restraint system).

Place anchorage in accordance with the construction documents. Where epoxy adhesives are used, follow the manufacturer’s installation instructions.

Next, set the panels in place and temporarily hold in place by tying the mesh on the panel to the mesh on the intersecting walls. After the roof/floor panels are installed, tie the partition walls to them as well. Finally, install all necessary angle mesh at the intersection walls and ceiling.

For walls placed on GCT Structural Building System floor panels, simply place the panels in the correct location and fasten to the floor, walls and ceiling using the angle mesh. Unless called out in the design of the building, use of rebar at the connections is not required.

REINFORCING MESHWORKS

In addition to the wall panels, wire mesh reinforcements are required at specified locations. These reinforcements come in a variety of shapes and sizes and are shipped to the jobsite along with the panels. Each of these reinforcements is designed for a specific purpose and is required at the following locations:

- Window/door corner reinforcement
- Window/door edge reinforcement
- Wall intersections
- Intersection of walls to floor or roof panels
- Free ends of walls
- Damaged or cut wire mesh.
- Other areas as required by the Registered Design Professional

Designed with galvanized steel wire, the meshwork is used to reinforce openings, corners and joints between panels to provide continuity to the structural meshwork. “C” clips or hog rings are used to attach the meshwork to the panels. The following standard meshwork accessories are adequate for most situations. If necessary, meshwork can be custom made to meet the needs in unusual situations.

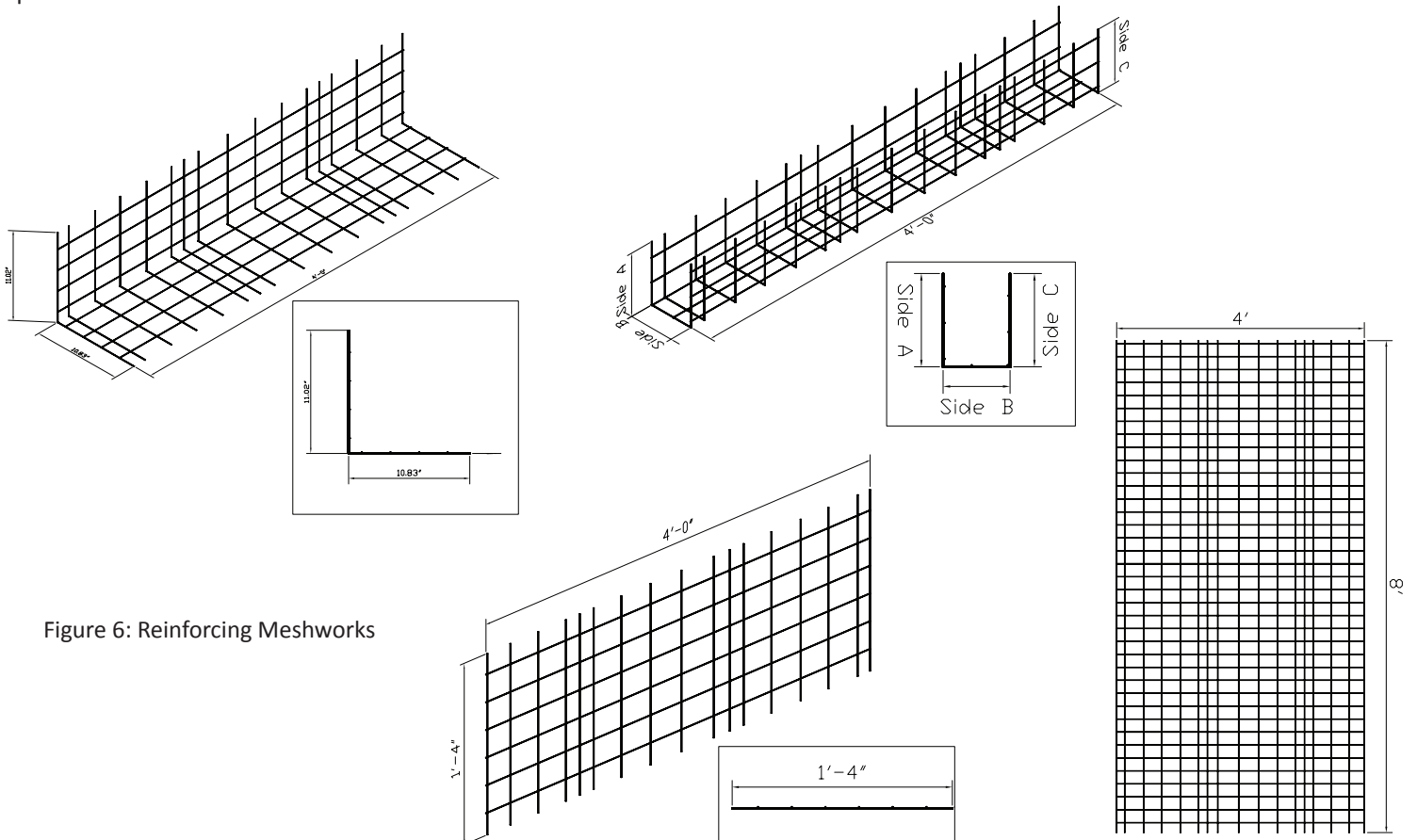

Figure 6: Reinforcing Meshworks

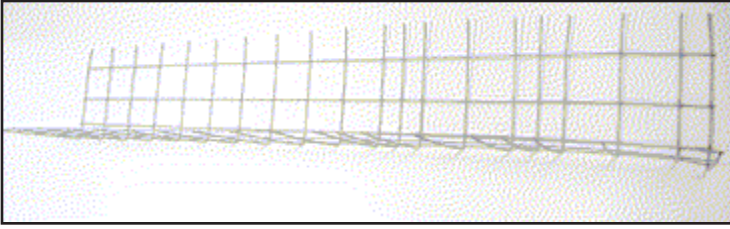

Photo 6: RG1 - Angular Meshwork

ANGULAR MESHWORK RG1

All the building internal and external corners, either vertical or horizontal, are reinforced along the full length with angular mesh (RG1), which ties to the structural mesh of the panels. Similar to connecting panels together, connecting angular mesh to the wire mesh of the panels can be carried out using pneumatic tools that use "C" clips or hog rings, or by manually binding them with tie wire. The connections are carried out along the overlapped wires at 10" o.c. (one link every four wires).

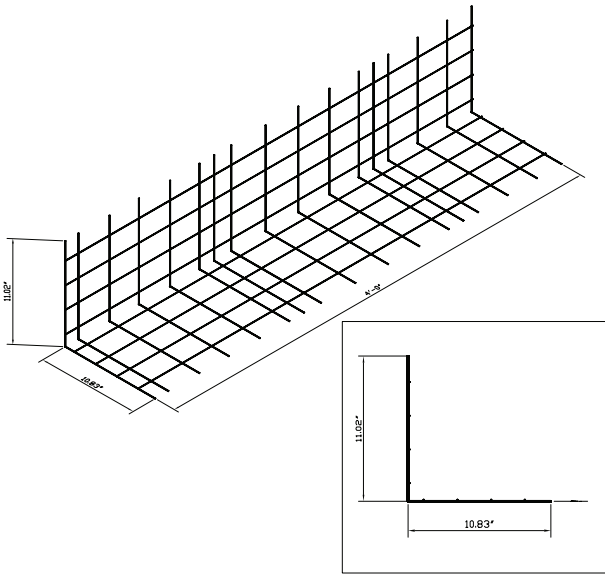

Figure 7: RG1 - Reinforces angle-connections.

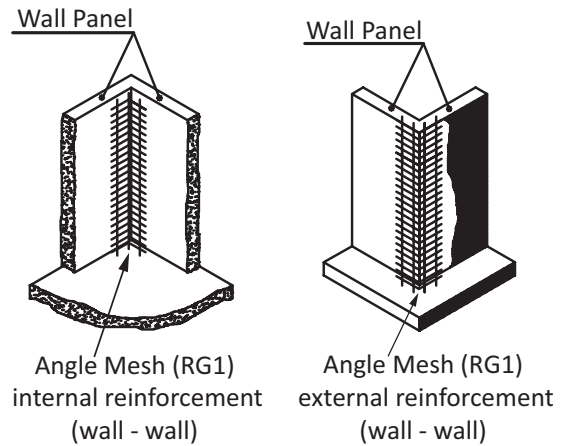
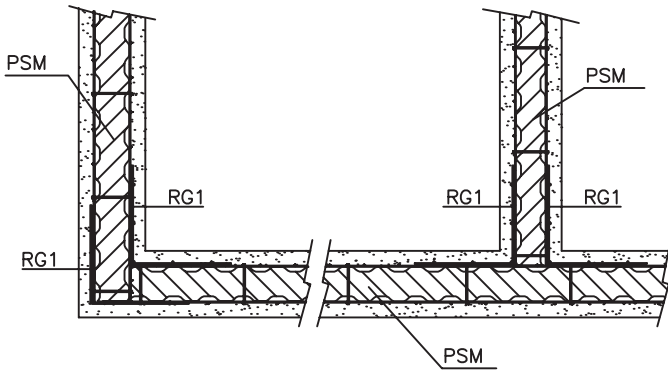

Figure 9: Typical Types of Mesh Used for Reinforcement/Connection



PANEL JOINTS (horizontal section)

Figure 8: PSM Panel Connection at Corners

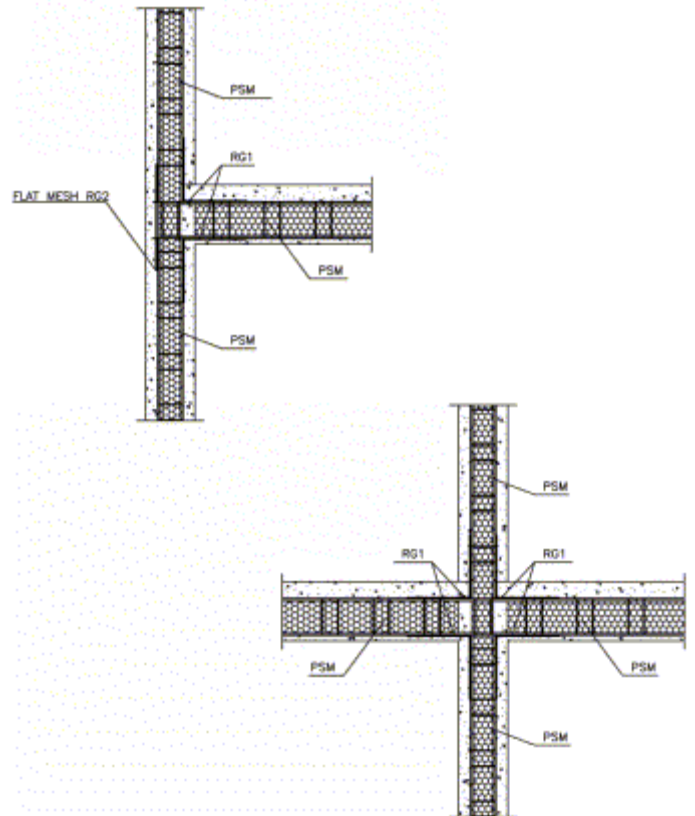

Figure 10: PSM Slab to PSM Wall Connection

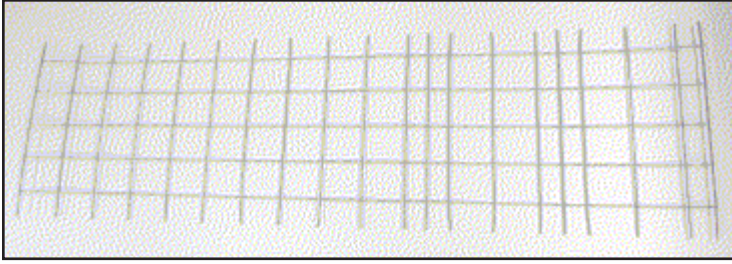

Photo 7: RG2 - Flat meshwork

FLAT MESHWORK RG2

Openings in GCT Structural Building System panels are all braced at each corner and on both sides, by positioning flat meshwork (RG2) at a 45° to the panel (see Figure 11). The window and door lintels (depending on their length), and window sills (whose span is longer than 4') shall be additionally reinforced per the engineered designs.

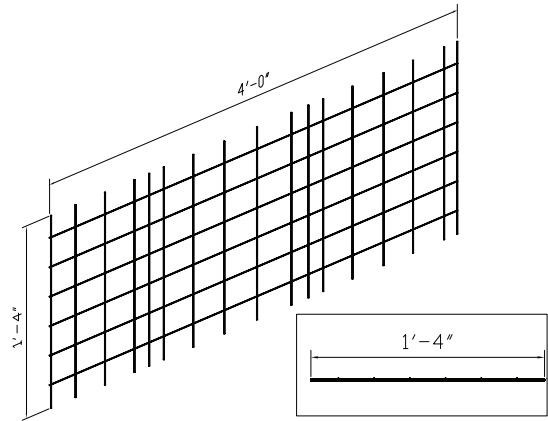

Figure 11: RG2 - Reinforces the corners of openings (placed at 45° angle to the corner), restores meshwork that had been previously cut and is suitable for any joints between panels.

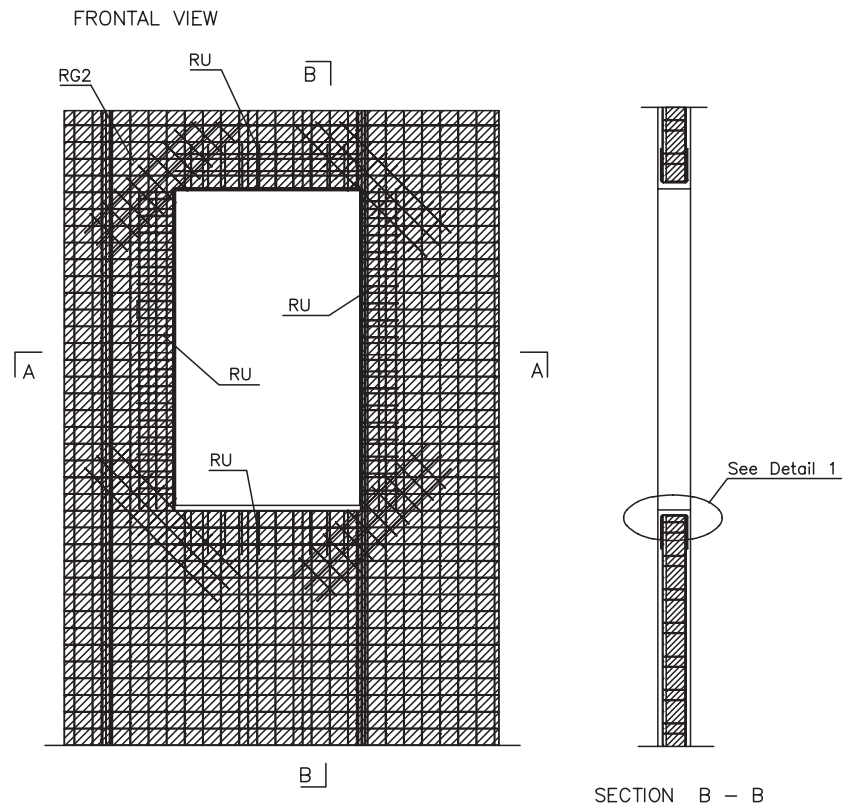
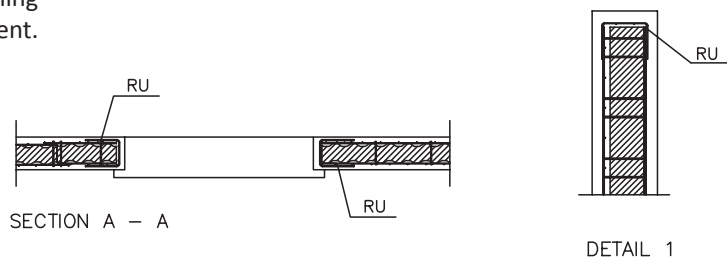

Figure 12: Example of window framing using RG1 and RG2 reinforcement.



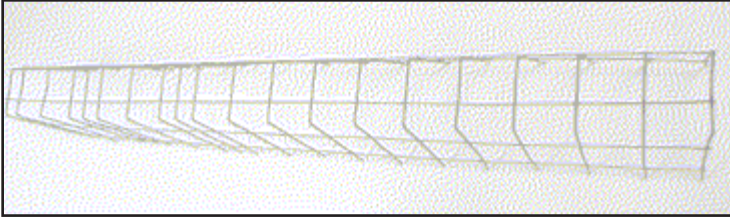

Photo 8: RG3 - U-shaped meshwork

“U” SHAPED MESHWORK RG3

Along the perimeter of the door and window openings, reinforcement U mesh shall be placed. For applications where specific fire resistance ratings are not required, openings may be finished prior to installation of the door frames. The door frames are attached using fasteners appropriate for connections to concrete. Where a specific fire resistance rating is required, the assembling of the door frames requires the polystyrene to be cut in the areas of the frame fastening points, to enable the correct insertion of metallic clamps inside the panel mesh. In this case the frames are installed first, and then the structural mortar is placed, embedding a portion of the frame in the structural mortar.

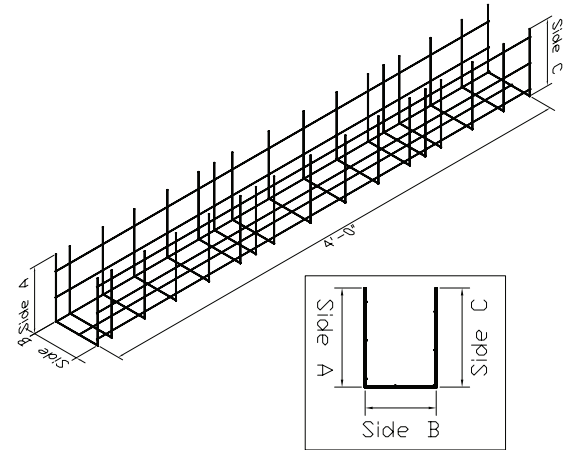

Figure 13: RG3 - Restores the continuity of the panels along the perimeter of openings like doors and windows.

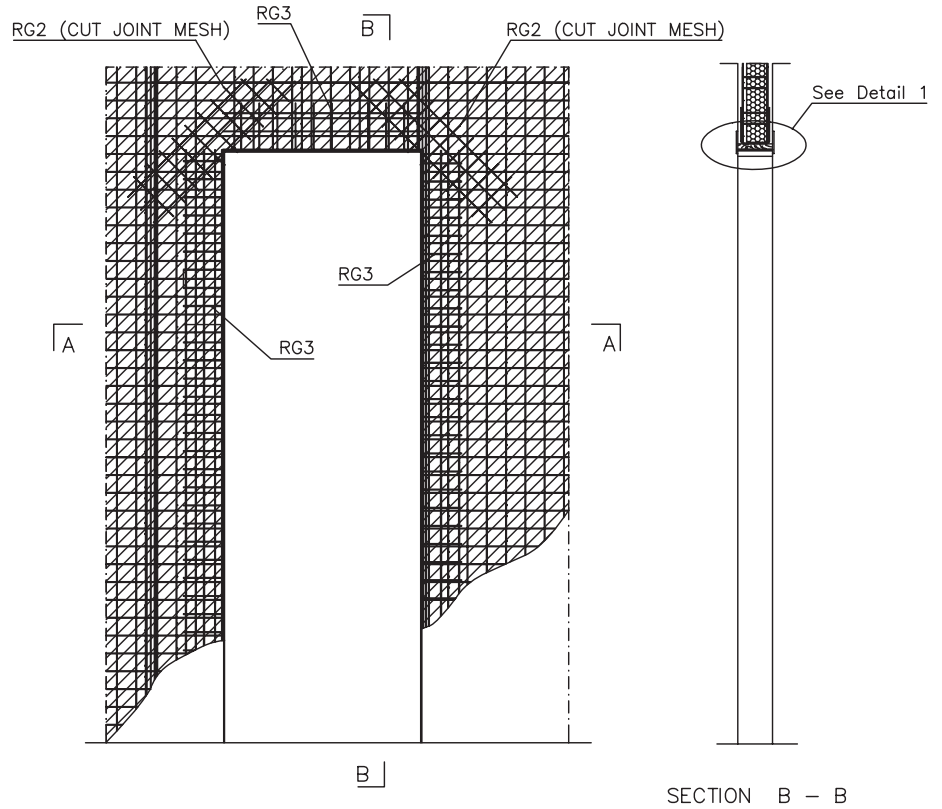
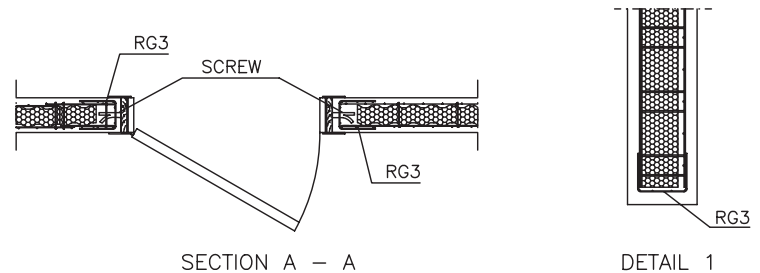

Figure 14: Example of door framing using RG3 and RG2 reinforcement.



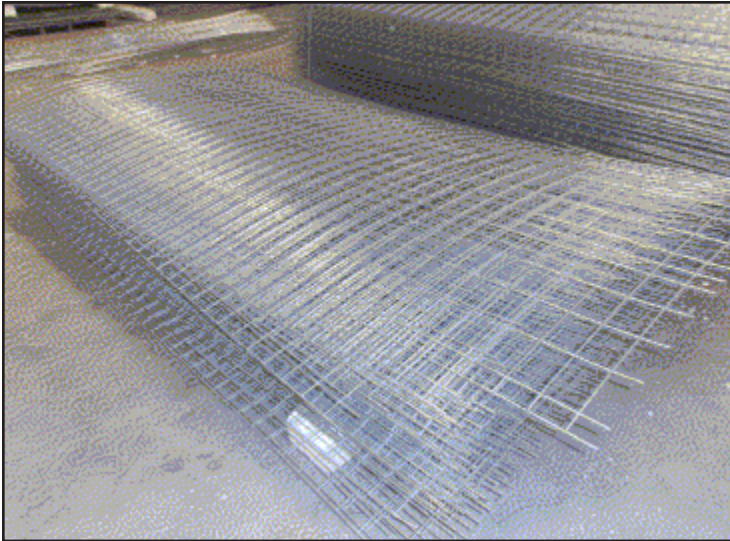

Photo 9: Reinforcing Meshwork

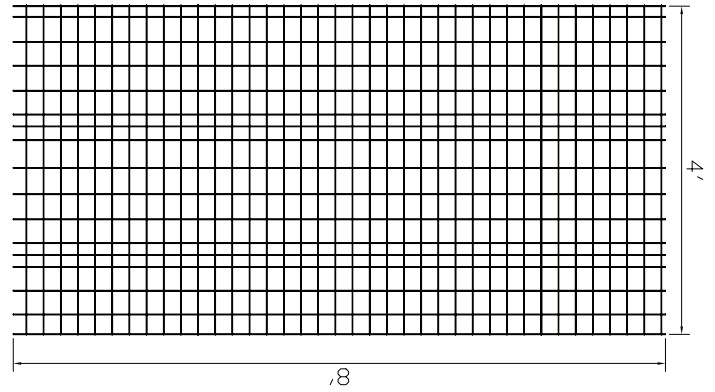

Figure 15: Reinforcing Meshwork - Restores the meshwork of bent panels and panels cut due to non-standard sizes (overhanging mesh cut off) and the installation of piping. Also adds additional reinforcement for the installation of heavy objects such as kitchen cabinets.

REINFORCING MESHWORK

For specific needs or types of frames that have special requirements, meshwork reinforcing parts can be custom made by contacting GCT for the appropriate design.

- Foundation only applications
 - Capping the walls
 - Preparation for accepting wood framing above
- Anchors embedded
- Anchors post installed

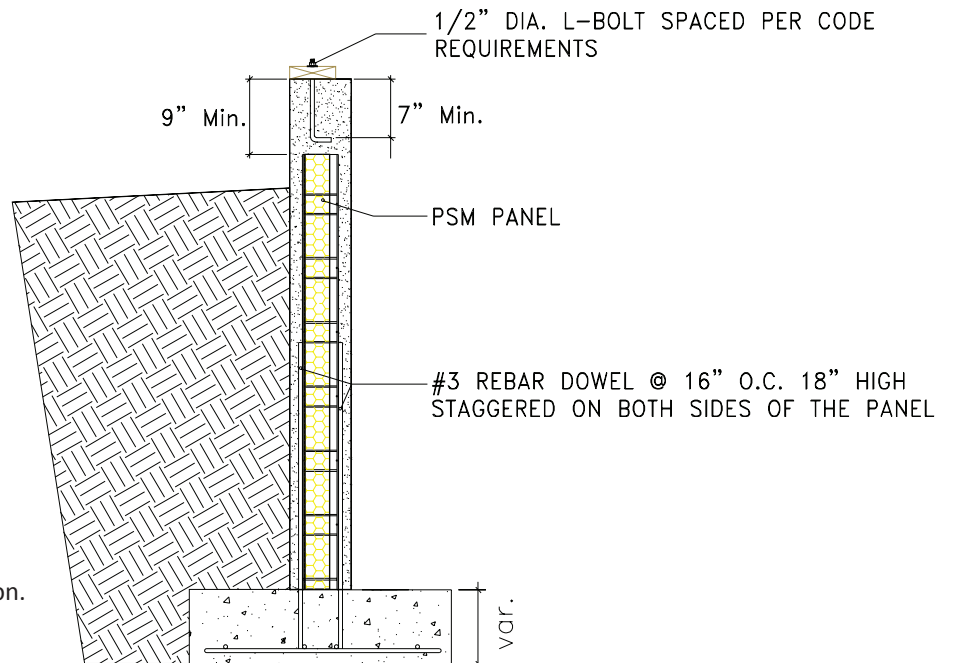

Figure 16: Standard Sill Plate Connection.



INSTALLATION OF GCT BUILDING SYSTEM FLOOR & ROOF SLABS (PSM, PSM HP OR PSG)

Connecting roof and floor panels together is done in the same manner as the installation of vertical panels. Set the first panel such that the overlapping mesh overhang is on the lower side of the roof/slab. The following panel

is then simply placed (from the top side) by setting the panel edge on the overlapping mesh of the preceding panel. Proceed by setting panels and connecting them to the adjacent panel one panel at a time. Roof and floor assemblies are then attached to the walls using angle reinforcement mesh (RG1) and/or rebar as required by the design. Where required by the design, install reinforcing in the panel joists. Panels should be oriented such that the length direction of the panel runs from support to support. The panels shall be shored up by bridge boards and placed on metal columns (jack posts). A camber at the rate of $\frac{1}{16}$ " per foot of the span of the floor length shall be supplied.

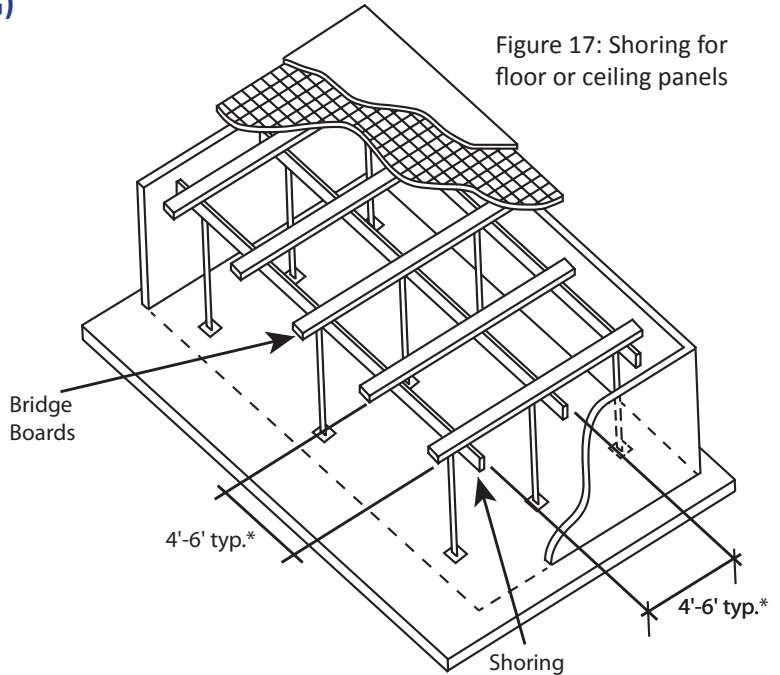

Figure 17: Shoring for floor or ceiling panels

*Example only - Shoring to be designed by a Registered Design Professional

ASSEMBLING FLOOR PANELS PSG

Begin by joining the individual panels to each other and then connect them to the walls with steel bars and/or reinforcement mesh. Rebar is then placed in the PSG joist cavities in accordance with the engineered design. Next, angle reinforcement mesh (RG1) is placed in the wall supports.

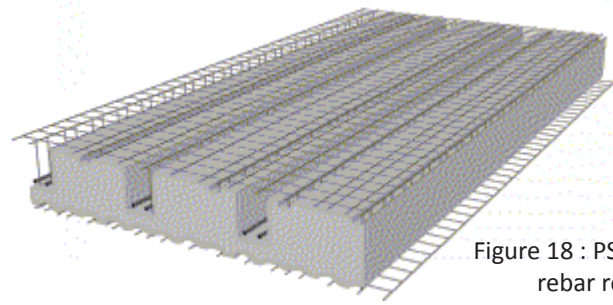

Figure 18 : PSG panel with rebar reinforcement

Place shoring on the underside of the floor and roof panels at intervals of 4' to 6', slightly increasing the shoring height at the center of the floor so the panels have a slight camber ($\frac{1}{16}$ " for each foot of half the total span). A roof frame will then be made with bridge boards placed at 4' to 6' on center and perpendicular to the shoring. Spray the scratch coat on the underside of the floor and allow curing. Once the lower side mortar has sufficiently cured, concrete may be placed on the upper side of the floor. Concrete having a minimum compressive strength of 3500 psi and a maximum aggregate diameter of less than 0.5" is then poured over the PSG panels to the depth indicated on the construction documents (typically 2" over the meshwork). Do not pour the floor thicker than the structural plans indicate. Once the floor is finished and cured (after 28 days), the support shoring is gradually removed and installation of finish mortar on the underside may begin.

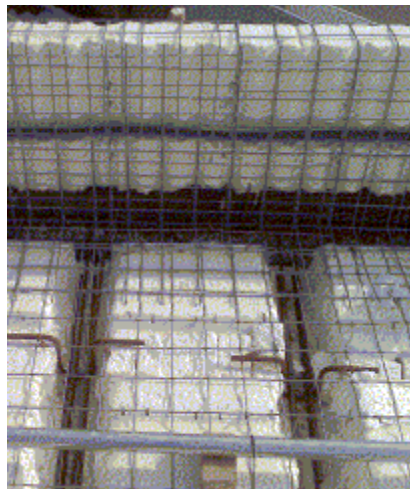

Photo 10: PSG Floor panels at parapet prior to concrete placement. Note reinforcement in joist cavities and the removal of the EPS to accept concrete at the parapet.



Photo 11: Place shoring on the underside of the floor and roof panels at intervals of 4-6'.

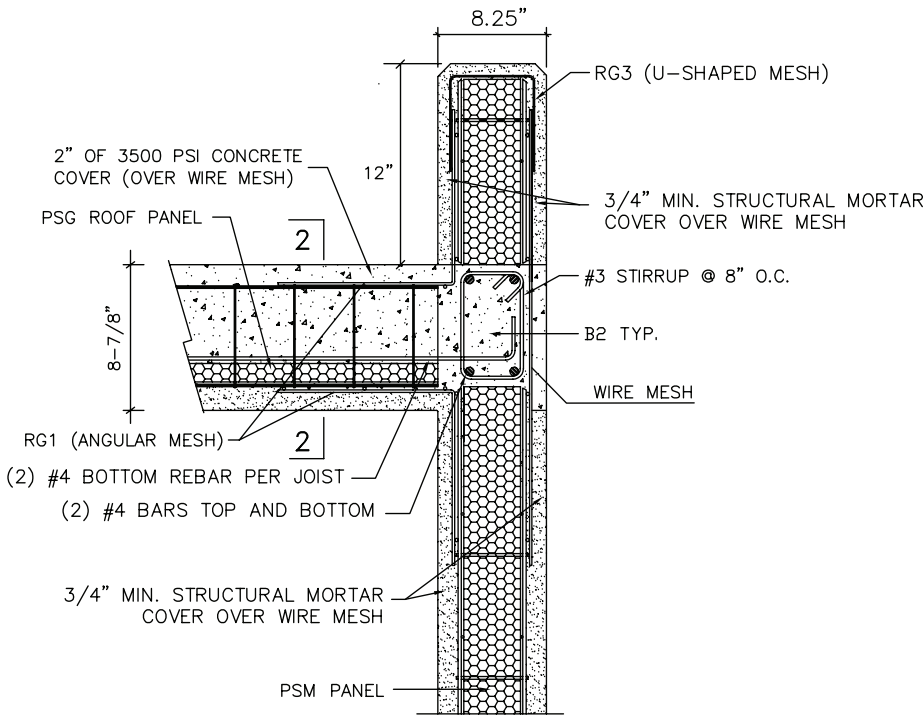

Figure 19a : Example of PSG Floor/Roof attachment where PSG joist is perpendicular to the wall.

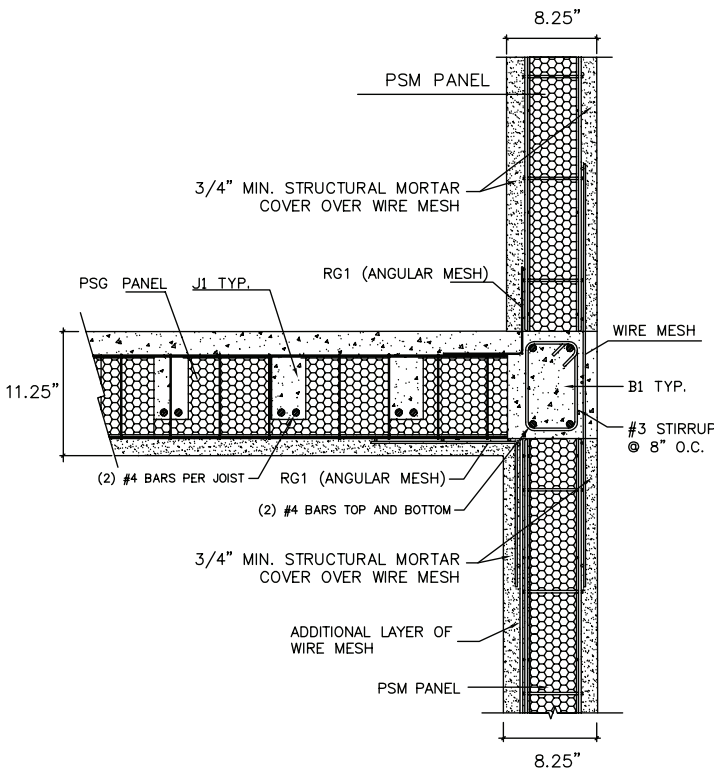

Figure 19b: Example of PSG Floor/Roof attachment where PSG joist is parallel to the wall.

FINISHING THE WALLS

- Ensure that the walls are plumb and level and the appropriate bracing is in place.
- Check that all of the required meshwork has been installed. Required meshwork includes U-mesh around the perimeter of all window and door openings, angle mesh at all wall to roof or wall to floor connections. Flat corner mesh for each corner of all window and door openings, flat mesh for repairing any cut mesh, and any other reinforcing needed per the supplied plans.
- Screed guides need to be placed at this moment to make sure that the proper thickness is reached.
- The mortar is then placed in two layers. The first layer is the scratch coat. This coat is applied, covering the reinforcing mesh, and then finished with 1/8" deep troweled grooves. (See photos 12 and 13).



Photo 12.

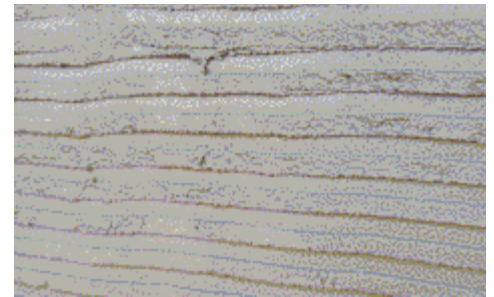

Photo 13.

- Proceed with the first application of the structural mortar to the outside face of the wall. If bracing has been placed on the exterior side of the wall, simply spray the mortar up to and around the bracing.
- Care should be taken to prevent large eccentricities in the wall by applying the scratch coat to both sides of the wall as soon as practicable.

- Once the scratch coat has sufficiently cured, the bracing can be removed.
- Apply the Modified Finishing Mortar to the walls, filling the strips where the bracing was placed. Ensure that the overall thickness of the mortar is as specified on the construction documents and all mesh has been covered with the required mortar thickness.
- The finish coat may be troweled smooth, or a pattern applied as desired.

FINISHING THE FLOORS

- Temporarily place shoring posts or shoring frames and beams at 4-6' intervals, slightly increasing the height of posts at the center of the floor slab at the rate of $\frac{1}{16}$ " per foot of floor span. The use of steel shoring posts is highly recommended to support the floors.
- Where the GCT single panels (PSM) are used, create roof scaffolding with bridge boards laid at 4-6' on center across the shoring posts and beams.
- The building designer should verify the floor panel reinforcement required and, if needed, should integrate it with additional reinforcement rebar inside the panel ribs (see Photo 14).

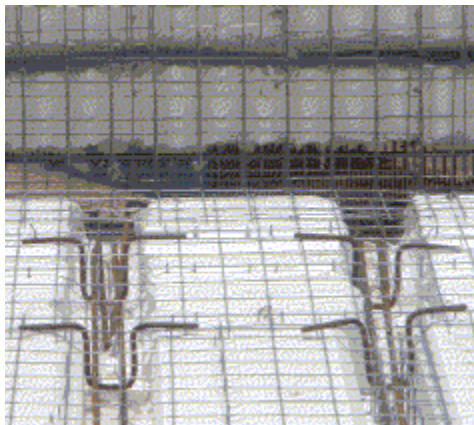

Photo 14.

- Proceed with the first application of the structural mortar to the lower face of the slab.
- Once the first application of mortar on the lower face has sufficiently cured, the concrete on the top side may be poured.

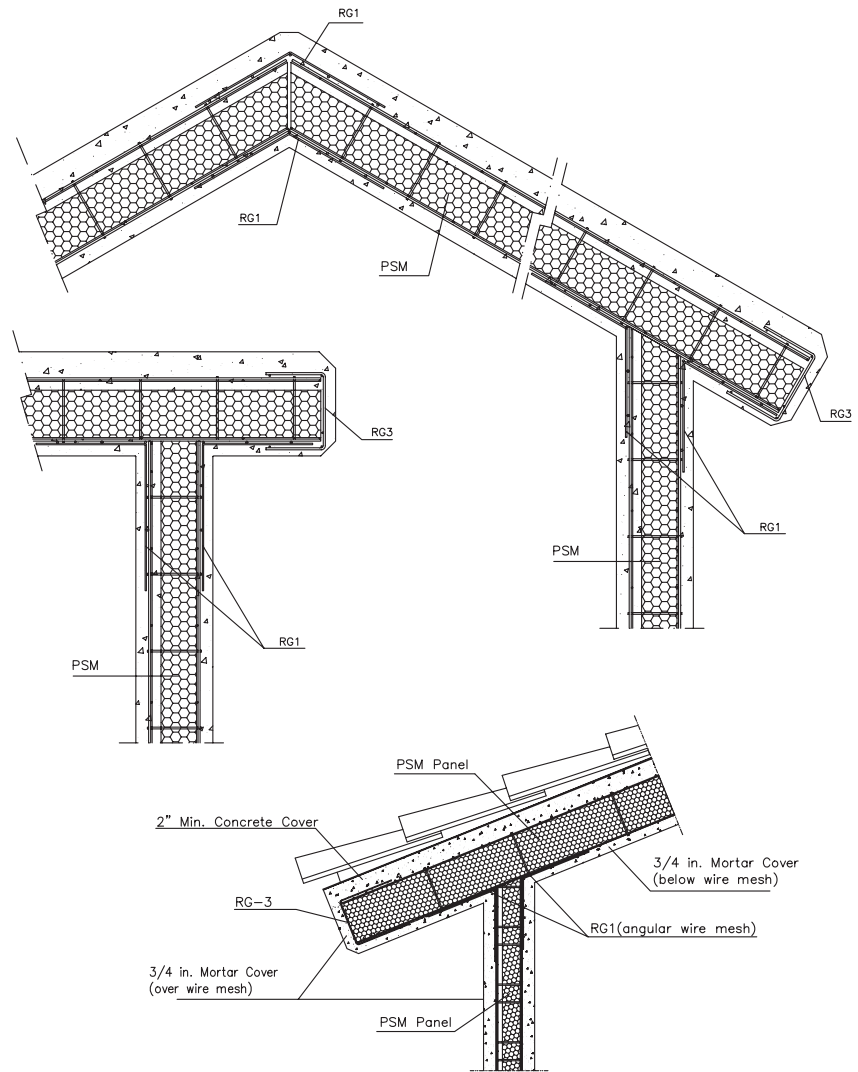

Figure 20: PSM Wall to PSM Roof Details

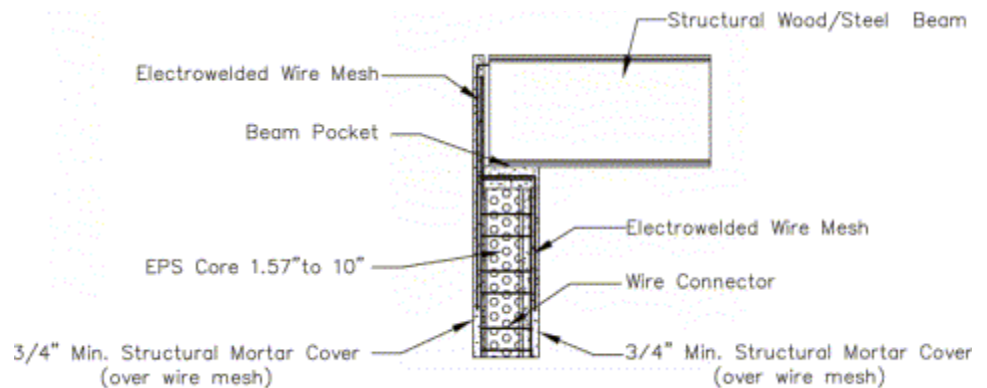
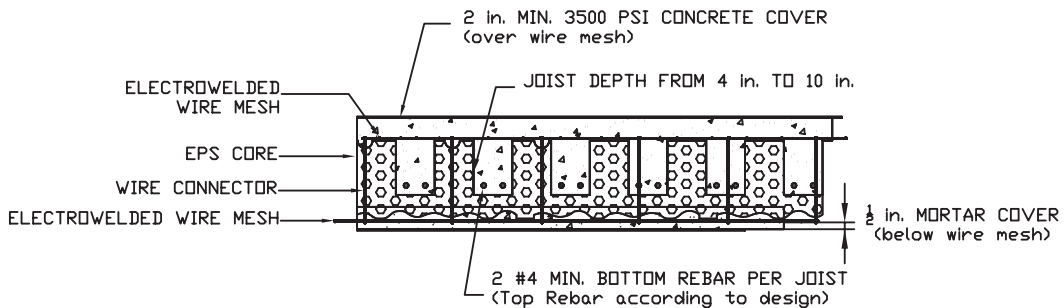
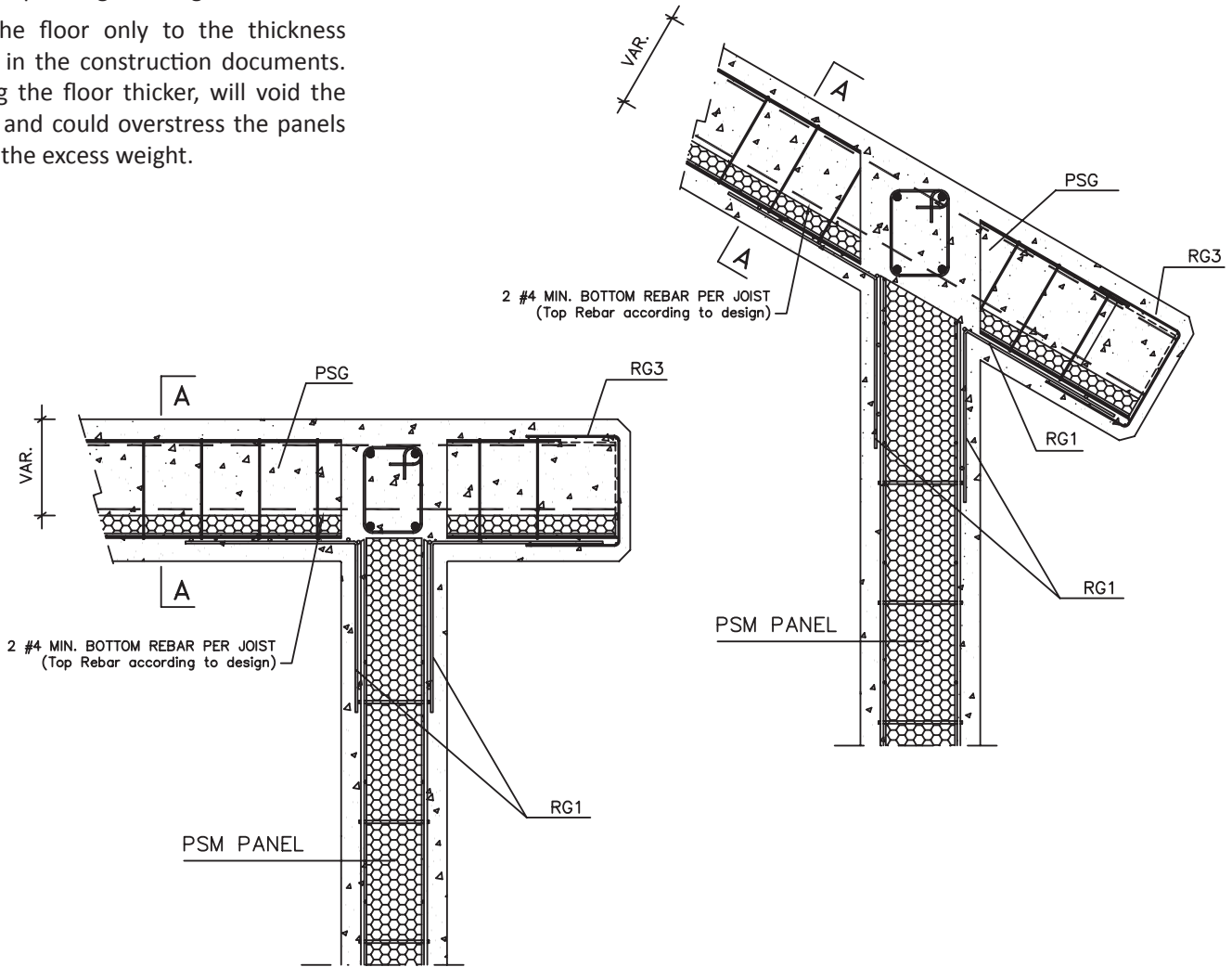

Figure 21: PSM Wall Section with Beam Pocket

- The upper face of floor panels requires the use of regular concrete having a compressive strength, $f'_c > 3500$ PSI, consistency S4, whose maximum aggregate-size measures 0.5" for a minimum thickness of 2" over the wire mesh, depending on design.
- Pour the floor only to the thickness shown in the construction documents. Pouring the floor thicker, will void the design and could overstress the panels due to the excess weight.
- Once the ceiling concrete has sufficiently cured (typically about 7 days unless additives are used), the posts can be removed starting from the center outward, so as to gradually transfer the load to the floor slab.
- Then complete by applying the Modified Finishing Mortar on the lower face of slab, filling the strips where the shoring boards were placed. This second coat of structural mortar on the lower side of the floor slab shall be carried out in the same manner as the walls.



SECTION A-A

Figure 22: PSG Roof Connection to PSM Wall

INSTALLATION OF GCT STAIR PANELS

The stair panels are used up to 20' in length, with a live load of up to 80 psf. Once the stair panel is assembled and the rebar is placed inside the panel ribs, it is completed with cast-in-place concrete as specified by the Registered Design Professional. Shoring is then installed at the rate of one every 4'. Concrete may be poured inside the stair ribs once the shoring on the landing panels is in place. For stairway spans greater than 10' we recommend cutting into the stair panel to provide access to the ribs, removing moderate portions of polystyrene. This will provide an access point for pouring concrete into the ribs, ensuring that the ribs are completely filled with concrete.

Once the stair ribs and landings have cured, mortar finish (1" thick) is then applied on both the sides and the bottom of the stair section. Marble flooring or tiles may be placed over a light mortar or cement plaster coat. As usual, allow the scratch coat to cure before removing shoring. Once the shoring has been removed, the finish coat may be applied.

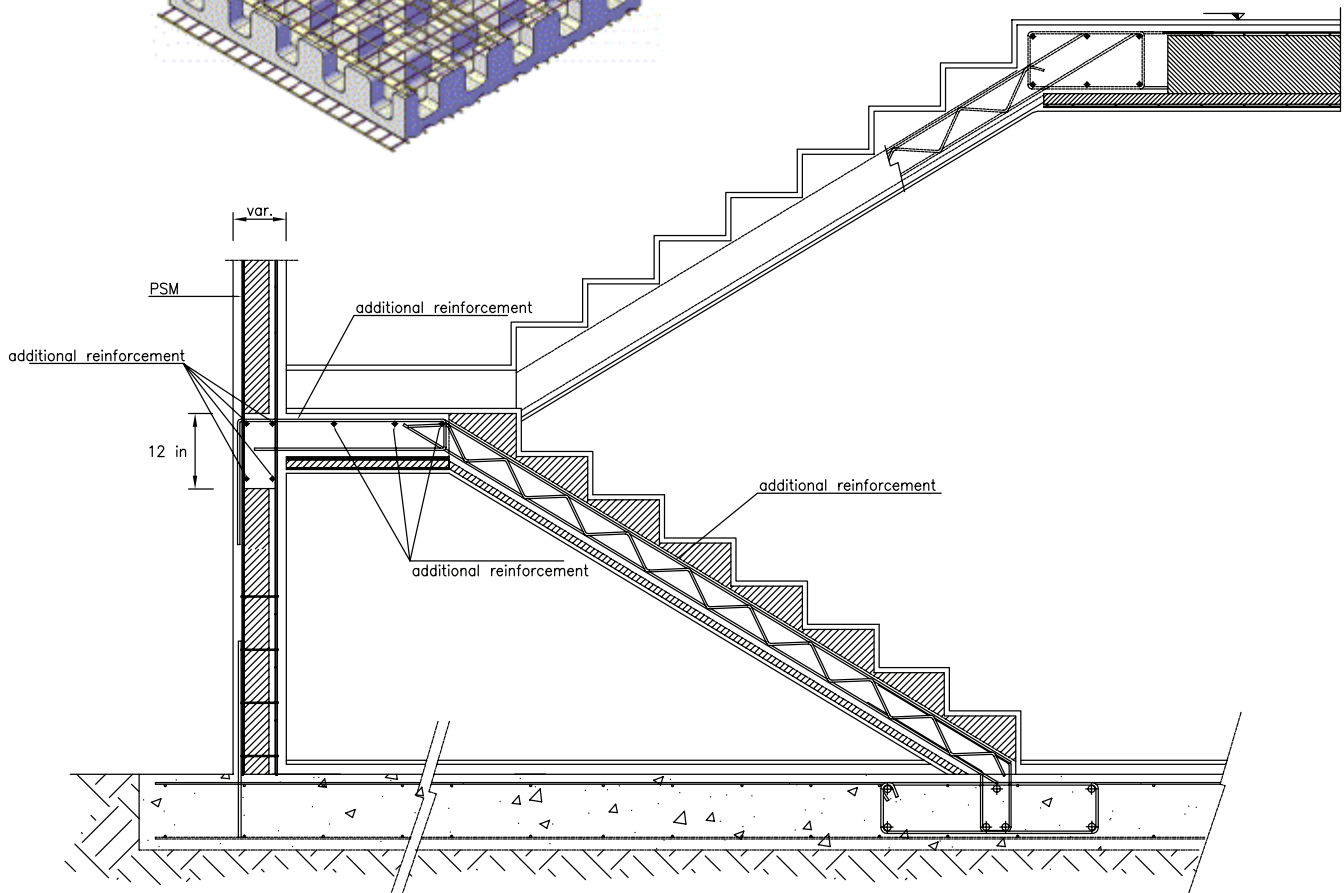
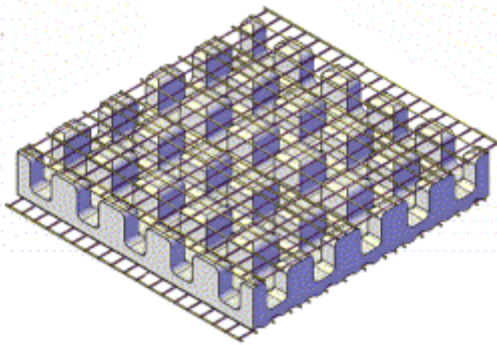
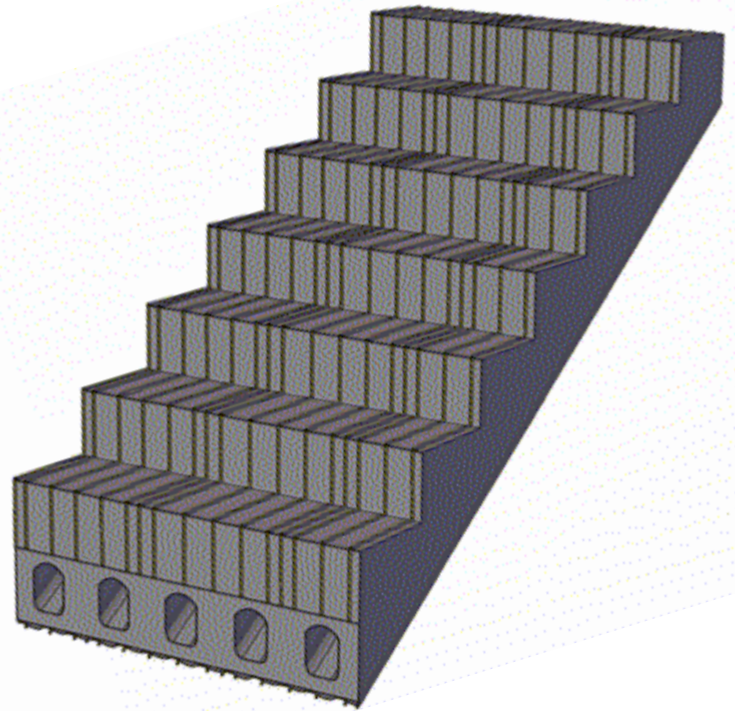

Figure 23: Section View Stair panel installation

DETAILS OF BALCONIES

The balconies are constructed by using the GCT floor panel (PSG) with additional anchoring bars attached to the adjoining floor. The quantity and diameter of these bars depend on the length of the cantilever and the required live load to be supported as determined by the Registered Design Professional. Proceed with the removal of shoring and placement of the second layer of mortar cover on the lower side of the slab only after the concrete placed on the top side is completely hardened.

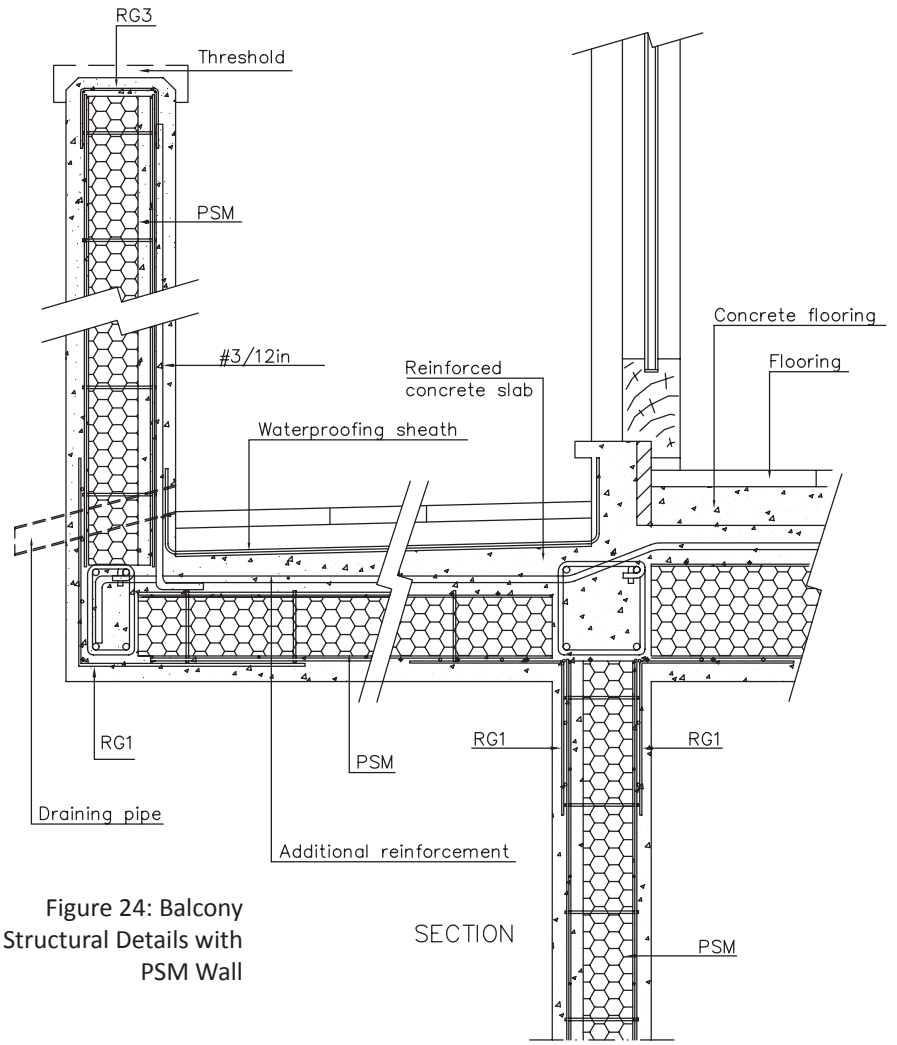

Figure 24: Balcony Structural Details with PSM Wall

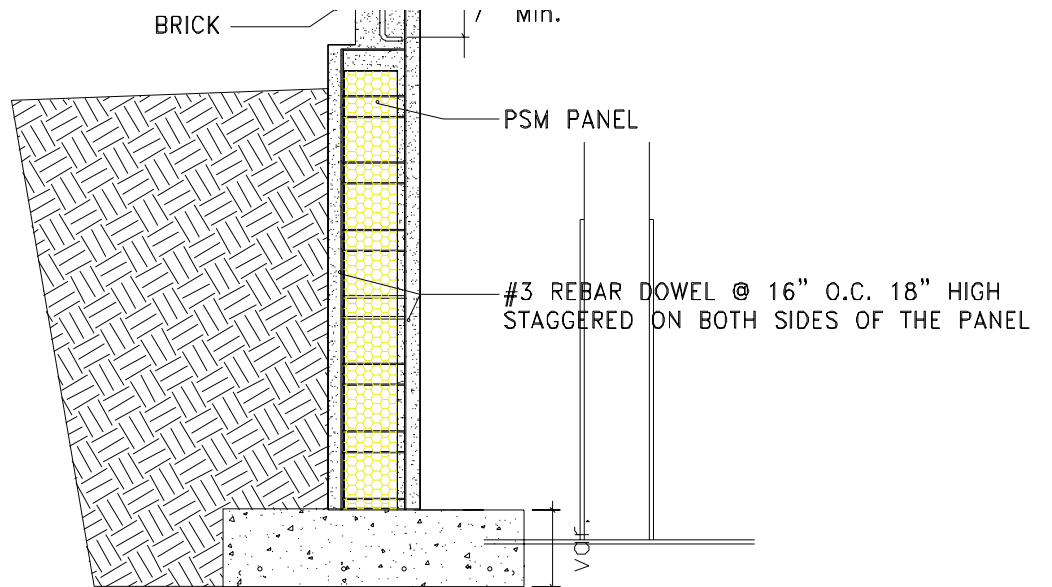
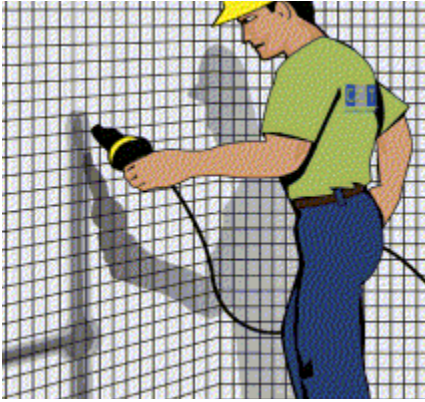

Figure 25: Brick Ledge Detail with Anchorage to Foundation

PLUMBING, ELECTRIC INSTALLATION & OTHER SYSTEMS



- The flexible piping for the electrical system, as well as the rigid piping for the plumbing and HVAC systems, is installed after the complete assembly of the panels and before the application of structural mortar.

- Chases for running the plumbing and electrical lines are created by using a properly sized heat gun to remove the EPS. Care should be taken to avoid creating voids that are larger than needed for the application. In all cases, a minimum of 1.6" of the EPS core shall remain in the wall. Do not use an open flame (torch) for this process as it is difficult to control the size of the chases.
- Flexible pipes are easily placed under the meshwork, whereas rigid ones are placed after cutting the mesh to allow access. Flexible plastic water lines are recommended for the water system due to the fact that a galvanic reaction will not occur. Once the supplemental systems have been installed, the meshwork needs to be restored by placing additional reinforcing mesh at each location where it has been cut and connecting it to the panel meshwork.
- Copper pipes must be insulated from the panel steel meshwork with felt, PVC or similar materials to prevent corrosion due to galvanic action. (See Photo 15.)
- Where pipes, conduit, electrical boxes, etc are too large to fit between the mesh and the EPS, cut the mesh and create a void in the wall by removing a portion of the EPS. Remove only the amount necessary to place the material. If an opening is cut too large, use a spray foam to fill in the voids. Any cuts on the mesh shall be replaced with flat reinforcement mesh (RG2) before applying the structural mortar. (See Photo 16.)

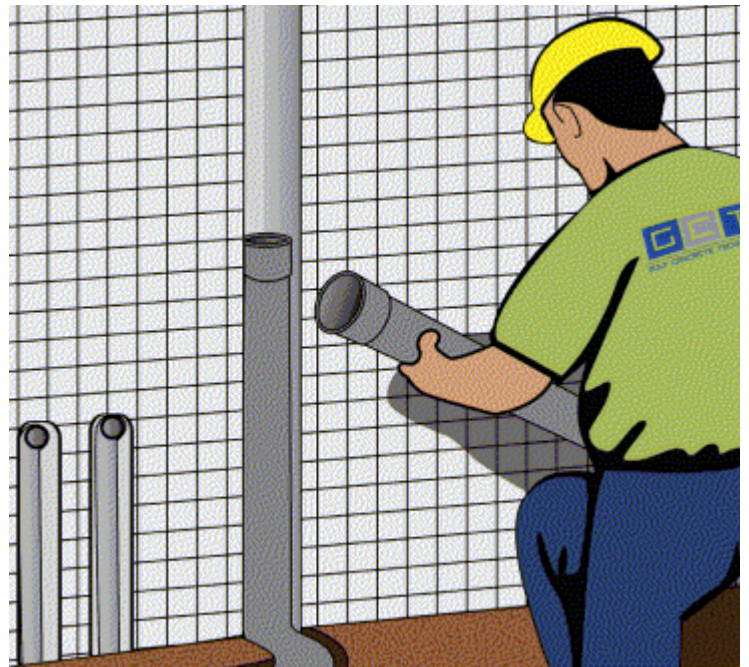

Photo 15.

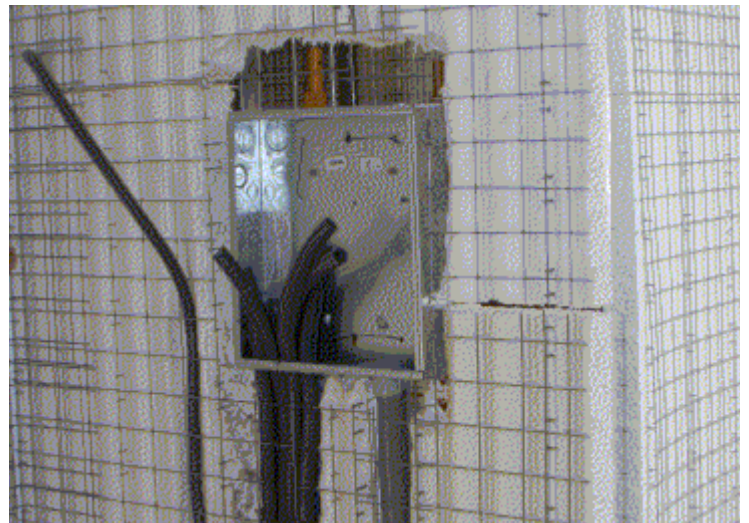

Photo 16.



FINISHING DETAILS

After the panels are assembled, the required reinforcing mesh-work is installed, the cut meshwork is restored and all details of the project are completed as required by the Registered Design Professional through the construction documents, structural mortar operations begin.

INSTRUCTIONS FOR MIXING CARMELO STRUCTURAL MORTAR MIX

A 50 lb. bag of Structural Mortar Mix will yield approximately 0.45 ft³ of mixed material. Coverage will be approximately 4 sq. ft. at 1-³/₈" thickness.

Machine Mixing Instructions: The optimal mixture is obtained by putting water in a clean container and then gradually adding the powder. Approximately one gallon of water is used for each 50 lb. bag of Structural Mix. If the mortar becomes too difficult to mix, add additional water until the desired consistency is achieved. The mixing process can be performed in a mortar mixer or in a bucket (working manually or with a mechanical agitator) or using a continuous mixer until homogeneous, lump-free mortar is obtained. It is also possible to use a mortar sprayer like the M-Tec mortar application equipment to mix and simultaneously pump the mortar, using a rotor/stator system appropriate for the size of the aggregate in the mixture.

Hand Mixing Instructions: Empty mortar bags into a suitable mixing container. Add approximately 1 gallon of water for each 50 lb. bag of Structural Mix to be used. Work the mix with the necessary tools, and add additional water as needed until the desired consistency is achieved. Make sure all the material is adequately wet before proceeding with the application.

APPLICATION

On both sides of vertical panels, a layer of Carmelo structural mortar should be sprayed to an average thickness of 1". Once the first layer has set up, a second layer is applied to the depth specified on the construction documents. This layering is done to prevent the mortar mix from running down the wall under its own weight.

The first layer of mortar should be scratched to allow mechanical bonding, and the interval between the spraying of the first and second layer should be as short as possible to minimize any concern related to adherence between the layers. If this is a concern, use a bonding agent. Before applying a finishing layer with materials other than structural mortar, wait until the structural mortar is completely hardened to avoid cracks from forming in the finish caused by shrinking of the underlying layers during curing.

Structural Mix must be applied with a trowel or by spraying, with subsequent passes, until the required thickness has been obtained. All cavities must be filled, the reinforcement rods must be carefully surrounded with the mortar and must be made compact, exercising adequate pressure during application.

Finish off the mortar as it begins to set, using the appropriate floating equipment (rigid float, sponge spreader or smooth spreader). Structural Mix must be applied after having moistened the substrate to saturation point.

STRUCTURAL MORTAR MIX CURING

Proper curing of the Structural Mortar Mix is crucial to obtain the necessary structural quality of the panels. In order to avoid an excessive evaporation from the mortar surfaces after the surface is completed, keep the walls and the ceilings constantly wet for at least two days from the application of the mortar layer. This procedure will complete the natural hydration process of the cement and will reduce cracking due to hydraulic shrinkage. Whenever anti-evaporating films are used, check subsequent finish application for any adhesion problems and correct in accordance with the requirements of the finish material manufacturer instructions. Do not apply Structural Mortar Mix when temperature is forecast to be above 100° F (38° C) without taking the required hot weather precautions. These typically require keeping the mortar applied to the structure wet to slow the curing process.

FINISHES

Paints and/or coatings on the structural mortar should be applied as late as possible. Longer intervals between cured mortar and the application of the coatings will better control shrinkage of the mortar. There will also be a greater certainty that the paint will adhere and the remaining micro-cracks will be more stable, with satisfactory aesthetic results.

OTHER CONSIDERATIONS

The use of Carmelo/GCT mortar sprayers for the application of the structural mortar increases the compactness and homogeneity, reduces the level of shrinkage, and increases both water and wear resistance.

Do not overload partition walls on one side only. Instead, apply mortar on both sides alternately.

If a panel is cut during erection and its meshwork has no wire crossing joints, panels may be joined with flat meshwork (min. width 9"). Highly-flexible coverings or paints can prevent the creation of small cracks in the mortar.

ATTACHING OBJECTS TO PARTITIONS

A. **Lightweight objects:** 1" long screws, pins or similar devices may be used.

B. **Heavy objects (shelves, water-tanks, toilets, etc.):** We recommend the use of plastic expansions with 1-3/4" long screws or similar devices (see Figure 25 below).

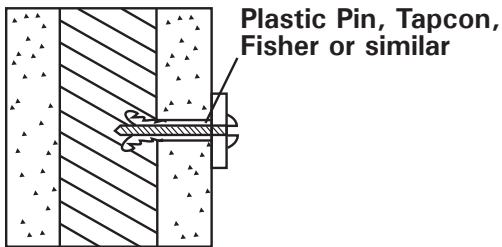

Figure 26.

C. **Extra heavy objects:** During construction, metal pins may be inserted in mortar pallets. Also, threaded pins can be fastened with epoxy resin (see Figure 26 below).

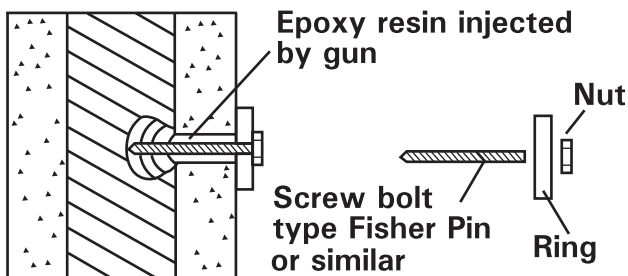
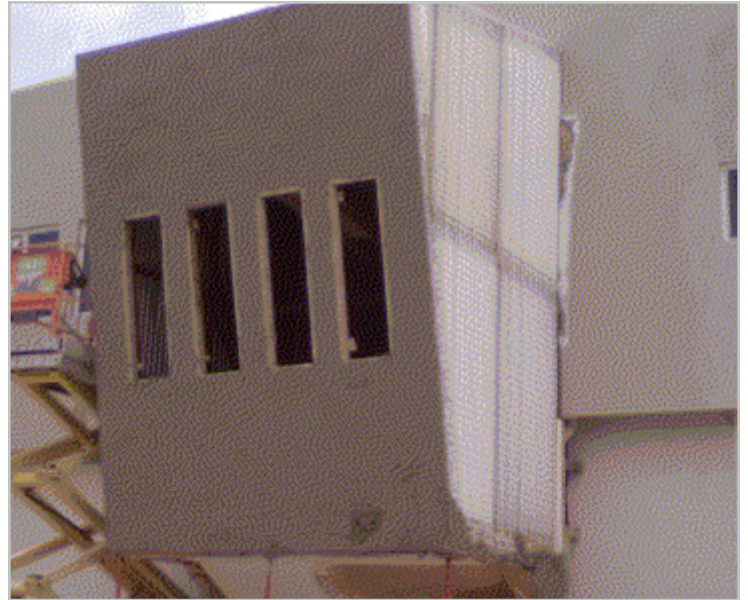

Figure 27.



CARMELO STRUCTURAL MORTAR MIX HIGH STRENGTH MORTAR (4000 PSI)

PRODUCT DESCRIPTION

Structural Mortar Mix is a single component, Portland cement-based, mortar containing additives for a superior bonding strength. Depending on application, Structural Mortar Mix may be sprayed or hand-troweled. The product contains microspheres with pozzolanic action making it less permeable and easy to place and finish. Packaged in 50 lb. bags, Structural Mix is simple to use, requiring only the addition of water at the jobsite.

PHYSICAL PROPERTIES

Structural Mortar Mix has a high degree of adhesion, shear and compression strength that ensures correct bonding of patched areas with existing structures. The durability of structural reinforcements obtained with Structural Mix is enhanced by the product's high levels of resistance to sulfate attack and chloride ingress.

YIELD

A 50 lb. bag will yield approximately 0.45 ft³ of mixed material. Coverage will be approximately 4 sq. ft. at 1-³/₈" thickness.

ADVANTAGES

- High compressive and bond strengths are achieved at a normal set time; with strength gains through 56 days.
- Low heat of hydration reduces the risk of shrinkage/thermal cracking.
- Excellent bond to concrete and other construction material substrates. Lowered rebound if used as shotcrete.

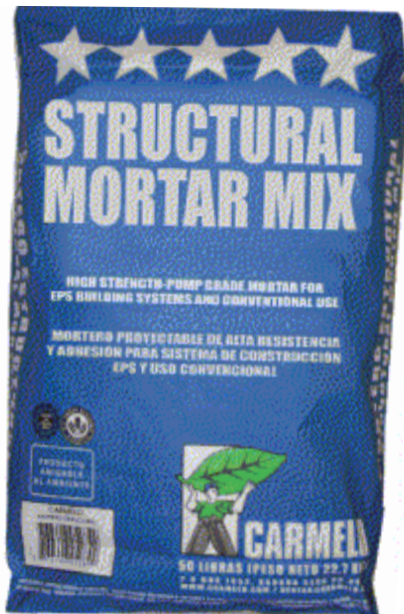

- Notable savings in material and labor on jobsite.
- Excellent finishing characteristics.
- Better adherence to the substrate.
- Improved workability.
- Environmentally friendly—contains recycled and regional materials such as aggregate.
- Minimal waste.

MACHINE MIXING INSTRUCTIONS

The optimal mixture is obtained by putting water in a clean container and then gradually adding the powder. Approximately one gallon of water is used for each 50 lb. bag of Structural Mix. If the mortar becomes too difficult to mix, add additional water until the desired consistency is achieved. The mixing process can be performed in a cement mixer or in a bucket (working manually or with a mechanical agitator) or using a continuous mixer until homogeneous, lump-free mortar is obtained. It is also possible to use a mortar sprayer to mix and simultaneously pump the mortar, using a rotor/stator system, like M-tec, suitable for the granulometric grading of the mixture.

HAND MIXING INSTRUCTIONS

Empty mortar bags into a suitable mixing container. Add approximately 1 gallon of water for each 50 lb. bag of Structural Mix to be used. Work the mix with the necessary tools, and add additional water as needed until the desired consistency is achieved. Make sure all the material is adequately wet before proceeding with the application.

APPLICATION

Structural Mix must be applied with a trowel or by spraying, with subsequent passes, until the required thickness has been obtained. All cavities must be filled, the reinforcement rods must be carefully surrounded with the mortar and must be made compact, exercising adequate pressure during application.

Finish off the mortar as it begins to set, using the appropriate floating equipment (rigid float, sponge spreader or smooth spreader). Structural Mix must be applied after having moistened the substrate to saturation point on the clean surface free of dirt or water.

CURING

Provide sufficient moisture to permit continuous hydration of the cementing materials and to minimize cracking. The effectiveness of the curing procedure will depend on climate and job conditions. Do not apply when temperature is forecast to be above 100° F (38° C) without taking the required hot weather precautions.

ADDITIONAL RECOMMENDATIONS.

If it rains, GCT recommends interrupting the work and covering what has already been completed in order to prevent the fresh structural mortar from washing away. The structural mortar should not be applied when the outside temperature is less than 39°F (4°C) or over 104°F (40°C).

When there is ventilation, the layer of structural mortar shall be kept damp or protected to minimize evaporation.

The floor slab can be finished with structural mortar only after having placed the angular mesh (RG1) connected to the vertical panels. In order to ensure that the layer of concrete is perfectly flat and applied to the correct thickness, guides shall be placed initially at a distance of about 5' on center. Alternatively, metallic profiles (screeds) can be used. Guides shall be removed them from the fresh mortar prior to hardening to avoid the subsequent formation of cracks.

With the exception of guides and braces used in the weaker portions of the wall (panels between the two openings, etc.), guides and the braces may be removed after 24 hours the structural mortar is applied.

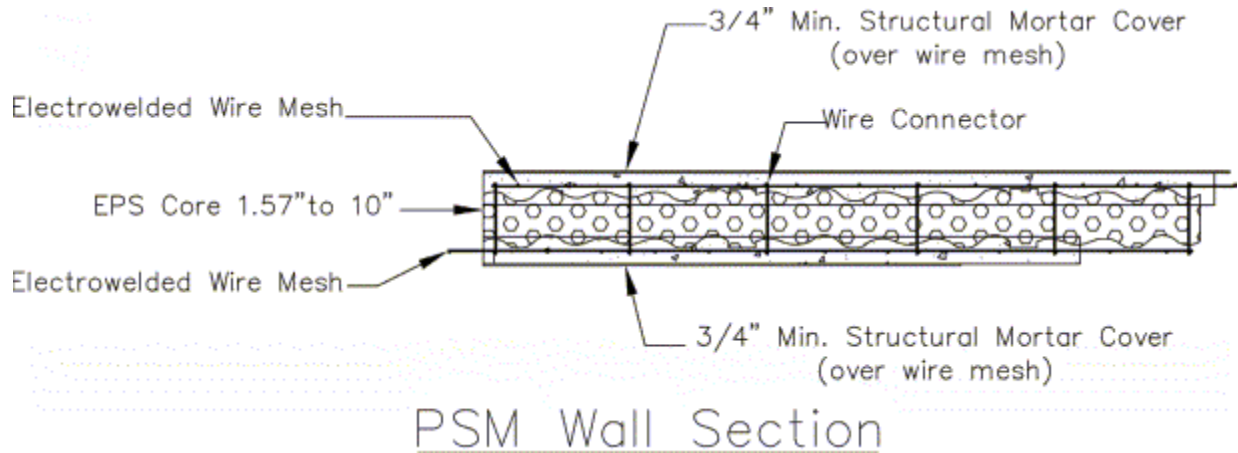

GALVANIZED STEEL WIRE MESH:

- Longitudinal wire diameter (panel length): 3.0 mm (11 gauge)
- Transversal wire diameter: 2.5 mm (12 gauge)
- Cross wire diameter: 3.0 mm (11 gauge) (approx. 6 per ft³ - 68 per m²)
- Steel wire yield: > 87 KSI (600 N/mm²)
- Steel wire fracture: > 98 KSI (680 N/mm²)

- EPS core density: Approx. 1 lb/ft³ (15 Kg/m³)
- EPS core thickness: Minimum 1.6 in. (40 mm)
- Finished masonry thickness: Minimum 4.3 in. (110 mm)

For the structural use of this panel, the EPS core should be at least 2" thick and an average thickness of Carmelo structural mortar of about 1.4" (at least 0.75" over the mesh) should be sprayed on each side having structural compressive strength of 4000 psi at 28 days.

The single panel (PSM) is generally used for buildings of no more than four stories. In areas where seismic design is required, and floor and roof slabs are used, they should have a maximum span of 13'. Additionally, the panel should be further reinforced with additional meshwork or rebar, and a thicker layer of concrete should be used on the upper side as required by the Registered Design Professional.

Panel Type	Minimum Expected Panel Finished Thickness (inches)	R-value	Fire resistance	STC
PSM 60	5.1	10	1 HR	> 48
PSM 80	5.9	12	1 HR	> 48
PSM 100	6.7	15	1 HR	> 48
PSM 120	7.5	18	1 HR	> 48
PSM 140	8.3	21	1 HR	> 48
PSM 160	9.1	24	1 HR	> 48
PSM 180	9.9	26	1 HR	> 48

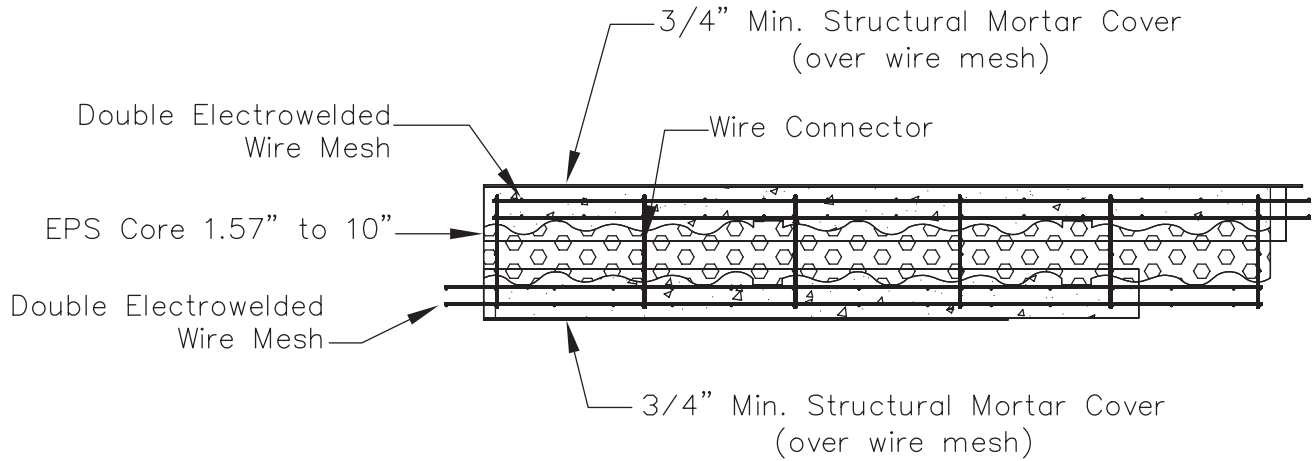

PSM HP Wall Section

GALVANIZED STEEL WIRE MESH:

Longitudinal wire diameter (panel length):	3.0 mm (11 gauge)
Transversal wire diameter:	2.5 mm (12 gauge)
Cross wire diameter:	3.0 mm (11 gauge) (approx. 6 per ft ³ - 68 per m ²)
Steel wire yield:	> 87 KSI (600 N/mm ²)
Steel wire fracture:	> 98 KSI (680 N/mm ²)
EPS core density:	Approx. 1 lb/ft ³ (15 Kg/m ³)
EPS core thickness:	Minimum 1.6 in. (40 mm)
Finished masonry thickness:	Minimum 6.5 in. (165 mm)

For the structural use of this panel, the EPS core should be at least 2" thick and an average thickness of Carmelo structural mortar of about 1.4" (at least 0.75" over the mesh) should be sprayed on each side having structural compressive strength of 4000 psi at 28 days.

The single panel (PSM) is generally used for buildings of no more than four stories. In areas where seismic design is required, and floor and roof slabs are used, they should have a maximum span of 13'. Additionally, the panel should be further reinforced with additional meshwork or rebar, and a thicker layer of concrete should be used on the upper side as required by the Registered Design Professional.

Panel Type	Minimum Expected Panel Finished Thickness (inches)	R-value	Fire resistance	STC
PSM HP 60	5.1	10	2 HR	> 48
PSM HP 80	5.9	12	2 HR	> 48
PSM HP 100	6.7	15	2 HR	> 48
PSM HP 120	7.5	18	2 HR	> 48
PSM HP 140	8.3	21	2 HR	> 48
PSM HP 160	9.1	24	2 HR	> 48
PSM HP 180	9.9	26	2 HR	> 48

SINGLE PANEL PSM SLAB

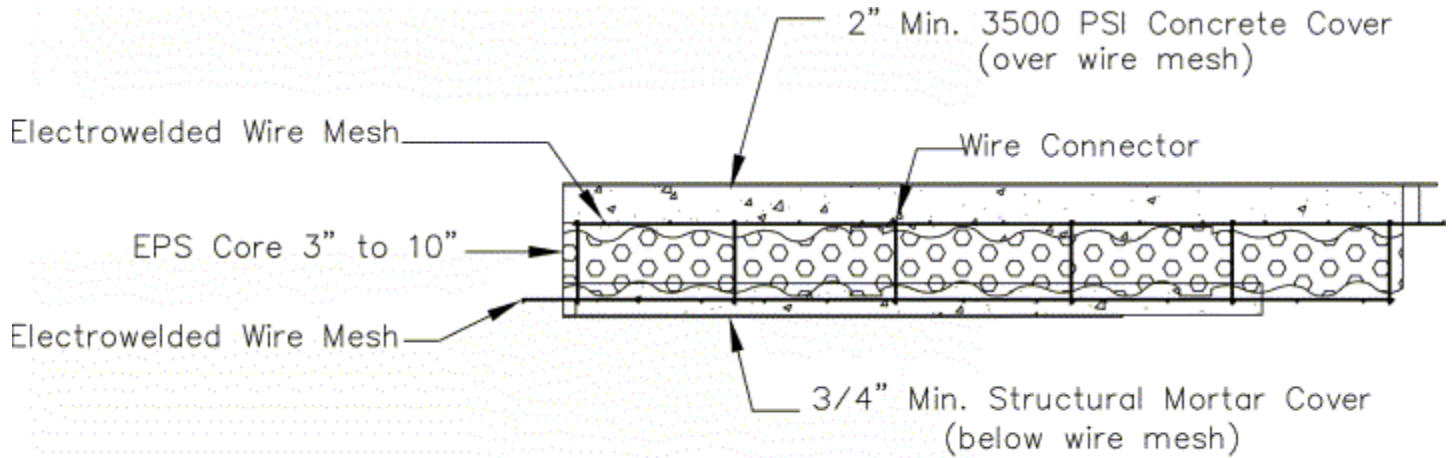

PSM Slab Section

GCT PSM panels are also used as floor or roof slabs. They are designated PSM SLAB consisting of EPS cores varying from 3" up to 10" thickness.

Working as floor slabs or a roof system, the upper side is poured with a concrete layer (3,500 psi) and will be 2.4" thick with at least 2" over the wire.

The lower side of the section will require a minimum of 0.75" of mortar cover under the outer face of the wire mesh.

Panel Type	Minimum Expected Panel Finished Thickness (inches)	R-value	Fire resistance	STC
PSM 100	8.0	16	1 HR	> 48
PSM 120	8.8	18	1 HR	> 48
PSM 140	9.6	21	1 HR	> 48
PSM 160	10.4	24	1 HR	> 48
PSM 180	11.2	27	1 HR	> 48

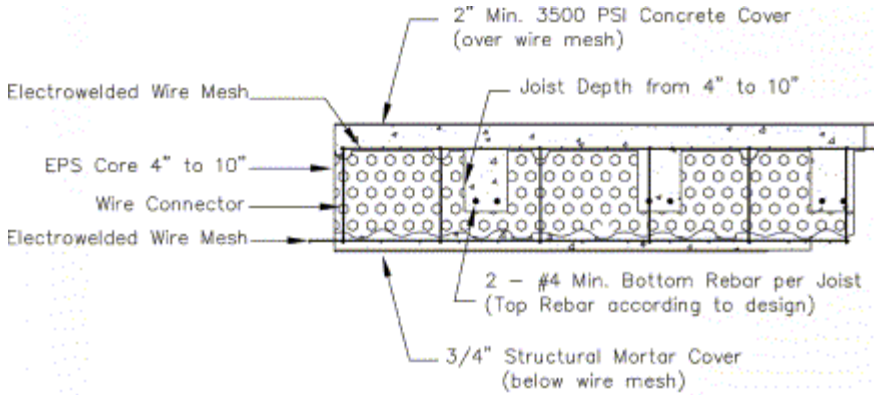

PSG3 Slab Section

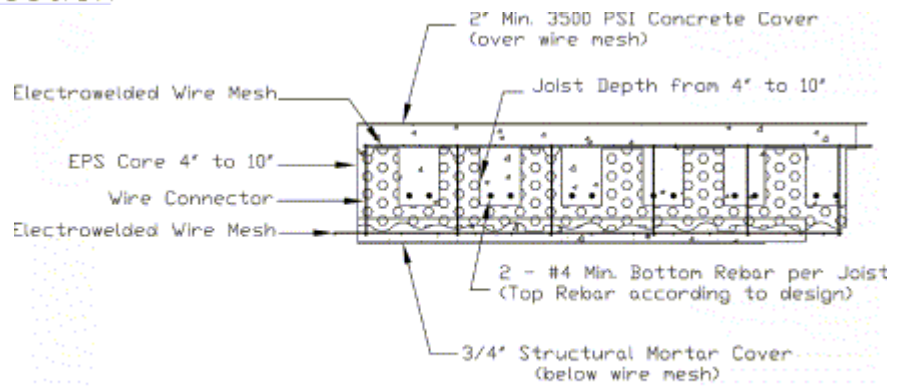

PSG6 Slab Section

GALVANIZED STEEL WIRE MESH:

Longitudinal wire diameter (panel length): 3.0 mm (11 gauge)
 Transversal wire diameter: 2.5 mm (12 gauge)
 Cross wire diameter: 3.0 mm (11 gauge)
 (approx. 6 per ft³ - 68 per m²)
 Steel wire yield: > 87 KSI (600 N/mm²)
 Steel wire fracture: > 98 KSI (680 N/mm²)

Polystyrene slab density: Approx. 1 lb/ft³ (15 Kg/m³)
 Soundproofing index: I > 38 dB at 500 Hz (in frequency band between 100 & 3150 Hz)

This type of panel is used for intermediate floor and roof systems and is strengthened in the joists with reinforced concrete beams cast on site. The reinforcement of the panel is integrated during the panel assembly by adding reinforcing bars (following the structural design) inside the joists. This solution is for floor slabs having spans up to 27 ft. and with live loads up to 82 lb/ft² (400 Kg/ m²). If a span needs to be extended, steel stiffening ribs in the panel joists may be used in order to sustain the loads. This must be verified by a the Registered Design Professional.

Panel Type	Min. Expected Panel Finished Thickness (in.)	R-value	Fire resistance
PSG2-100	10.0	20	1 HR
PSG2-140	11.5	24	1 HR
PSG2-160	12.3	27	1 HR
PSG2-200	13.9	31	1 HR
PSG2-240	15.5	36	1 HR
PSG3-100	10.0	18	1 HR
PSG3-140	11.5	23	1 HR
PSG3-160	12.3	25	1 HR
PSG3-200	13.9	29	1 HR
PSG3-240	15.5	34	1 HR
PSG6-100	10.0	12	1 HR
PSG6-140	11.5	16	1 HR
PSG6-160	12.3	17	1 HR
PSG6-200	13.9	18	1 HR
PSG6-240	15.5	21	1 HR

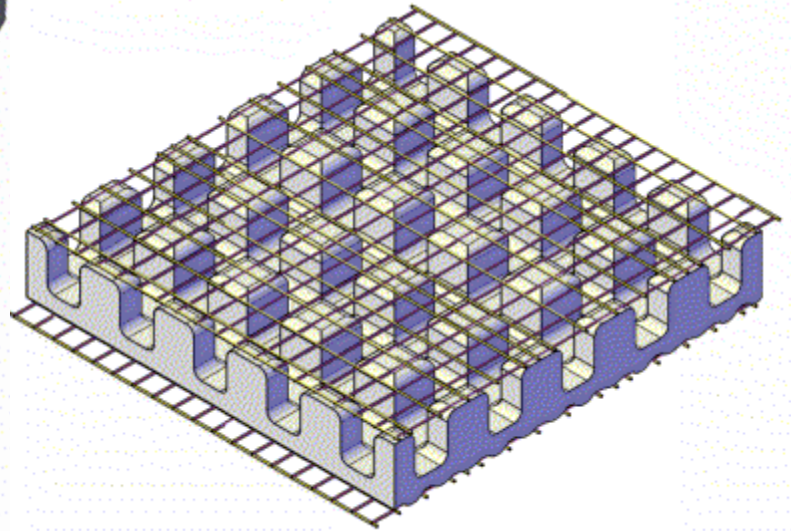
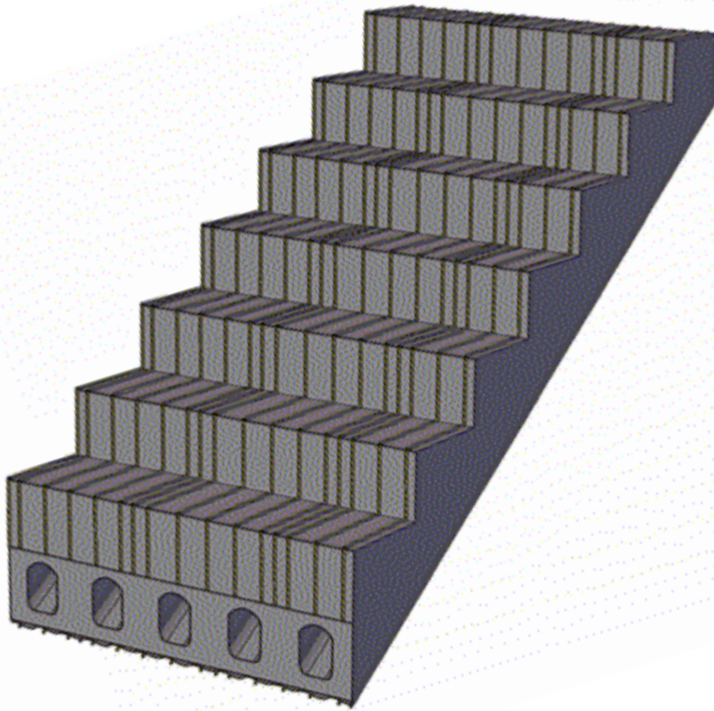

GALVANIZED STEEL WIRE MESH:

Longitudinal wire diameter (panel length):	3.0 mm (11 gauge)
Transversal wire diameter:	2.5 mm (12 gauge)
Cross wire diameter:	3.0 mm (11 gauge) (approx. 6 per ft ³ - 68 per m ²)
Steel wire yield:	> 87 KSI (600 N/mm ²)
Steel wire fracture:	> 98 KSI (680 N/mm ²)

Polystyrene slab density:	Approx. 1 lb/ft ³ (15 Kg/m ³)
Fire resistance REI:	120 (test conducted at Santiago del Chile University)

This panel consists of an expanded polystyrene block shaped according to the design requirements and reinforced by a steel mesh. The mesh on each side of the block is joined by steel wire connectors electro-fusion welded across the polystyrene core. Reinforced on the inside cavities and finished with casting on site, it is used for the construction of staircases up to a maximum span of 20' having a live load of 82 lb/ft² (400 Kg/ m²).



Structural
Panels GCT

GCT Structural Building System Technical Manual & Installation Guide

Version 1.0 • August 2012

Contact Us:

Manufacturing Plant:

4739 West Oreck Road Long Beach, MS 39560

Phone: 228-324-9696

Russell Scott Miller (Sales & Technical Advisor)
smiller@gctm2.com • Mobile: 904-742-4175

Ismael Vázquez, BSCE (Engineering Department)
ivazquez@carmelo.com • Mobile: 787-403-7671

Victor Camacho, P.E. (VP Sales & Operations)
vcamacho@carmelo.com • Mobile: 787-643-2684

www.structuralpanelsgct.com



CARMELO

Since 1955 serving Puerto Rico,
USA and the Caribbean

